

# Protein mass spectrometry and proteomics

L. Dayon

Spring Semester 2026

**EPFL**

# Course outline

## 1. Proteomics and mass spectrometry

Introduction to protein analysis and proteomics; Reminders in mass spectrometry; Why proteomics and mass spectrometry?; Ionization sources, analysers, and detectors used in proteomics; Latest generation of mass spectrometers used in proteomics

## 2. Mass spectrometry-based proteomic strategy and workflows

Bottom-up versus top-down strategies; Data-dependent acquisition (DDA) and data-independent acquisition (DIA) approaches; Sample preparation

Lab visit of the Proteomics Laboratory at Nestlé Research (EPFL Innovation Park)

## 3. Quantitative proteomic workflows

Label-free methods; Labelling-based techniques; Other quantitative techniques

## 4. Proteomic bioinformatics

Databases; Identification of protein; Quantification of proteins; Bioinformatics tools; Practical examples

## 5. Applications to biology, clinical research, and beyond

What strategy?; Experimental design & randomization; Biomarker discovery; Industrialized and population proteomics; Forensics; Targeted mass spectrometry-based approaches; Other biological applications of mass spectrometry; Advanced innovations (single-cells, 4D proteomics, multi-omics) and emerging technologies; Limitations and ethical consideration

Additional support/information on [Separations techniques in proteomics](#)

# Course outline

- Separations techniques in proteomics

Gel electrophoresis; Isoelectric focusing; Liquid chromatography (RP, IEX)

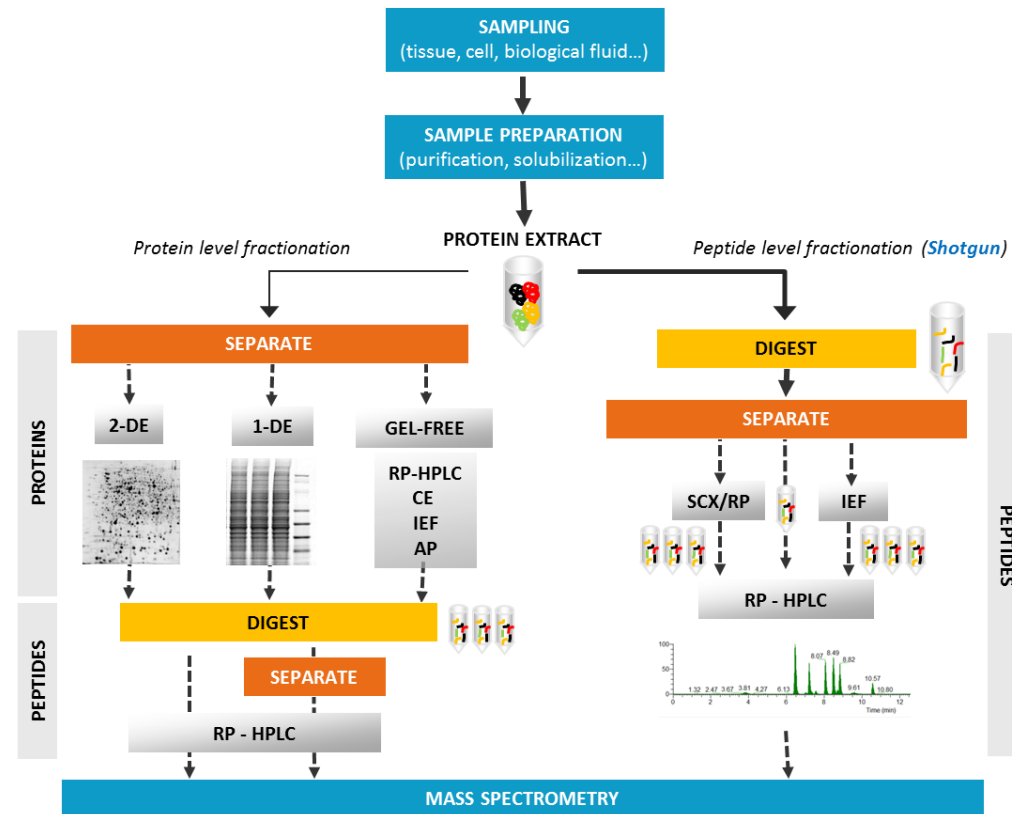

# Why separation?

## Diversity of sequences

- Arabidopsis ~28000 genes
- Human ~22000 genes
- Worm ~19000 genes
- Yeast ~6000 genes
- *E. Coli* ~5000 genes

Size of proteomes are much larger!

Heterogeneity in protein length, properties, localization...

Dynamic ranges of concentrations

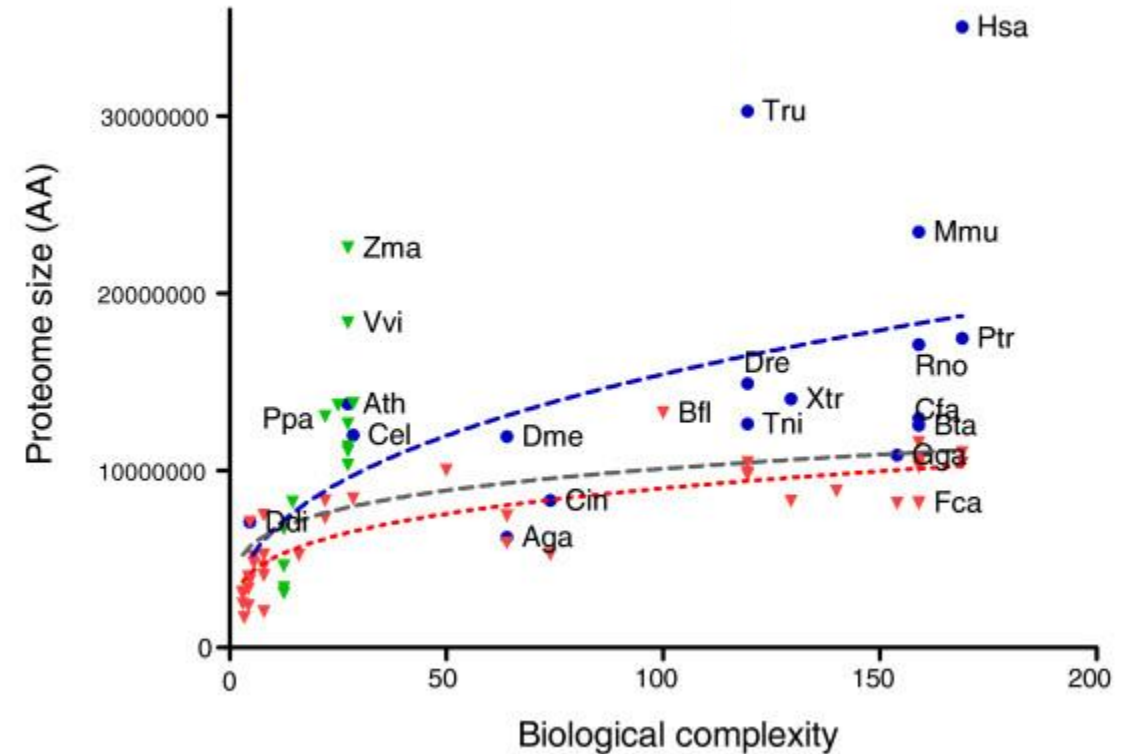

doi: 10.1186/gb-2011-12-12-r120

# 1. Gel electrophoresis

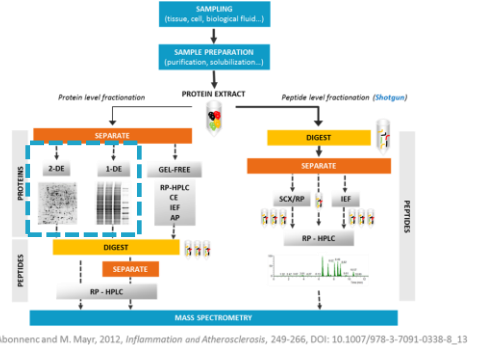

1D gel

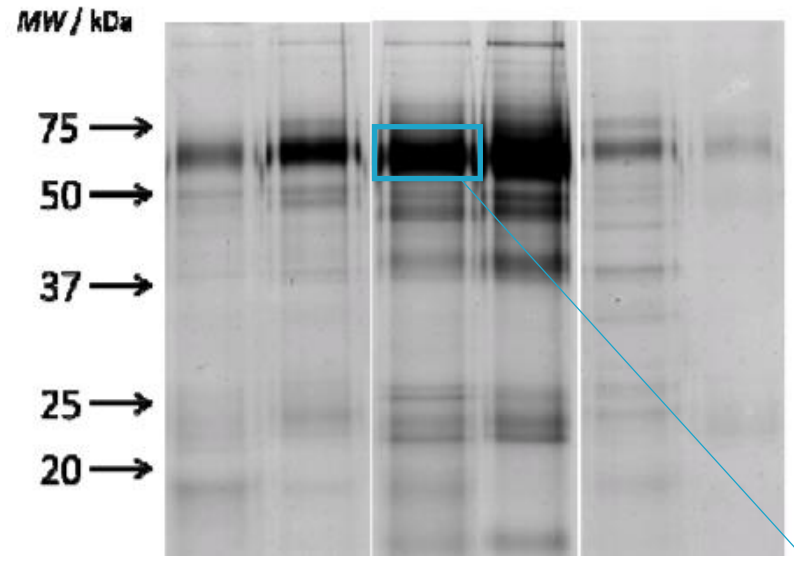

doi: 10.1021/pr101123t

Immunoblotting

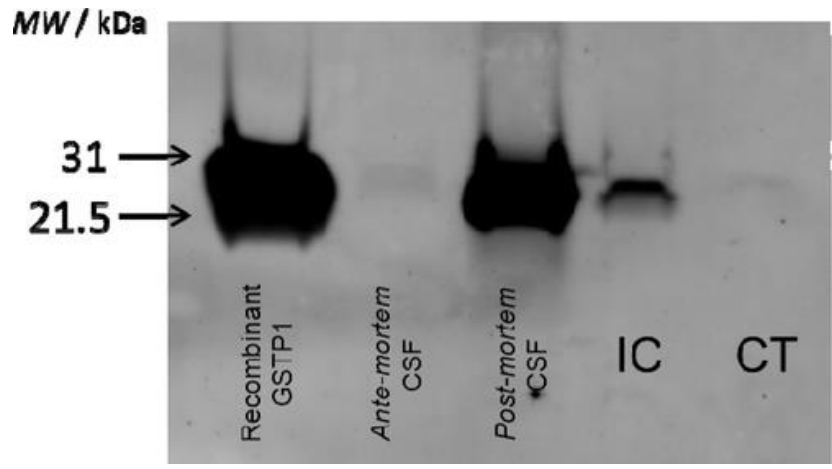

doi: 10.1021/pr101123t

2D gel

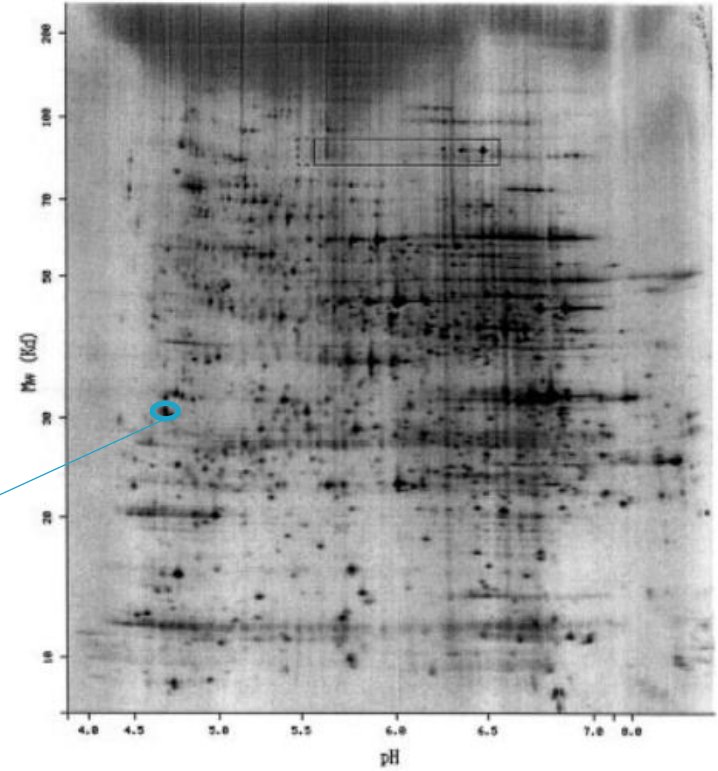

Nucleic Acids Res. 1996; 24(1): 180-181  
5

Mass spectrometry

# Electrophoresis

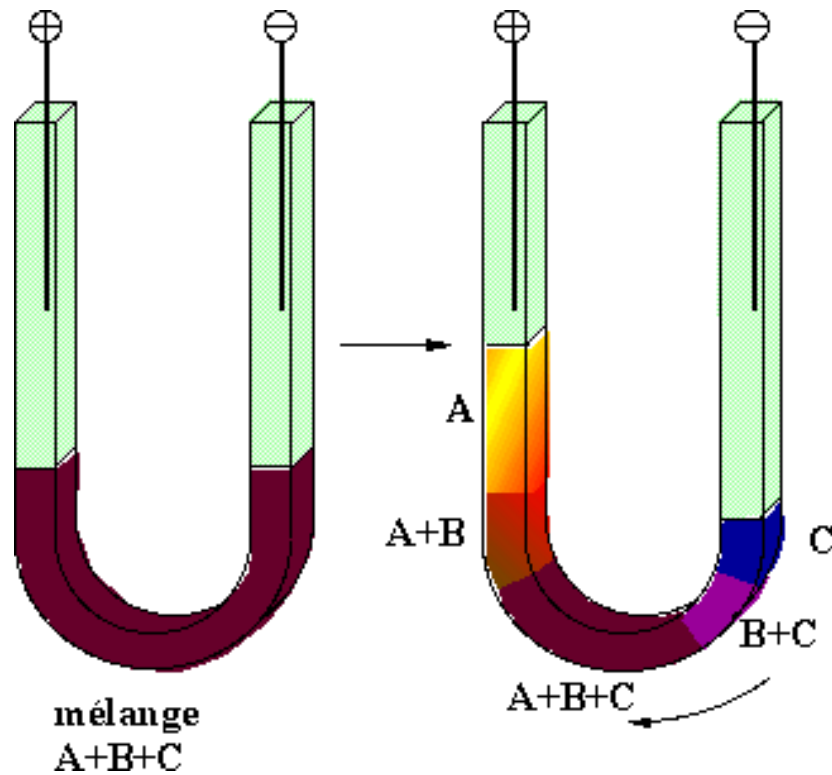

Protein separation  
of human serum



The Nobel Prize in  
Chemistry  
1948



Arne Wilhelm Kaurin Tiselius

"for his research on electrophoresis and adsorption analysis, especially for his discoveries concerning the complex nature of the serum proteins"

# Electrophoretic separation

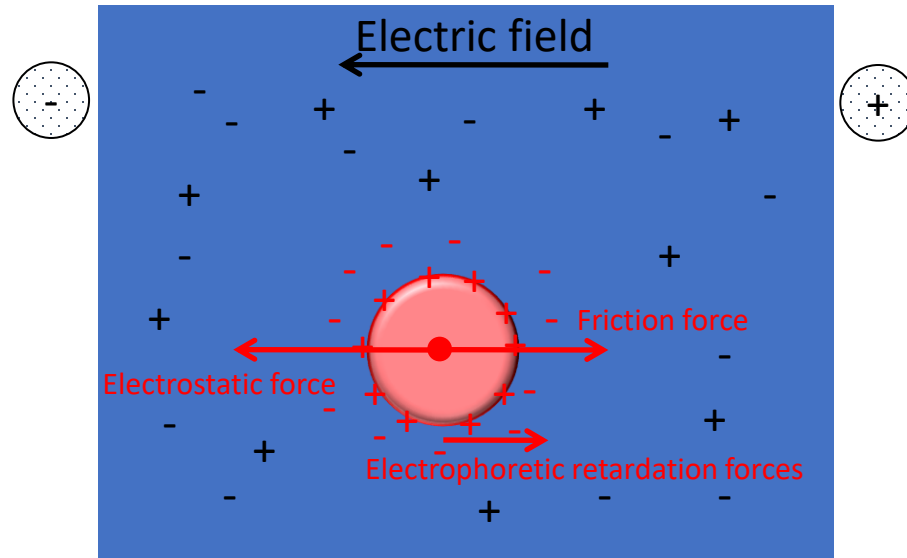

<http://en.wikipedia.org/wiki/Electrophoresis>

Electrophoresis is the motion of particles in an electric field

- 1) Electric field exerts **electrostatic force** on the particle through the carried charge
- 2) Hydrodynamic **friction force** affects all bodies moving in viscous fluids
- 3) Electrophoretic **retardation forces** are applied to the ions in the diffuse layer

Two main modes of electrophoretic separation are used for peptides and proteins:

**Zone electrophoresis** is based on the differences in the electrophoretic mobilities of charged species (analytes)

**Isoelectric focusing** is an electrophoretic technique for the separation of amphoteric analytes according to their isoelectric points

# Electrophoresis set-ups

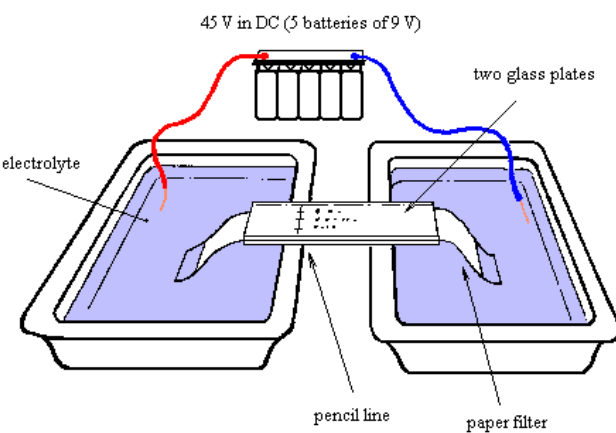
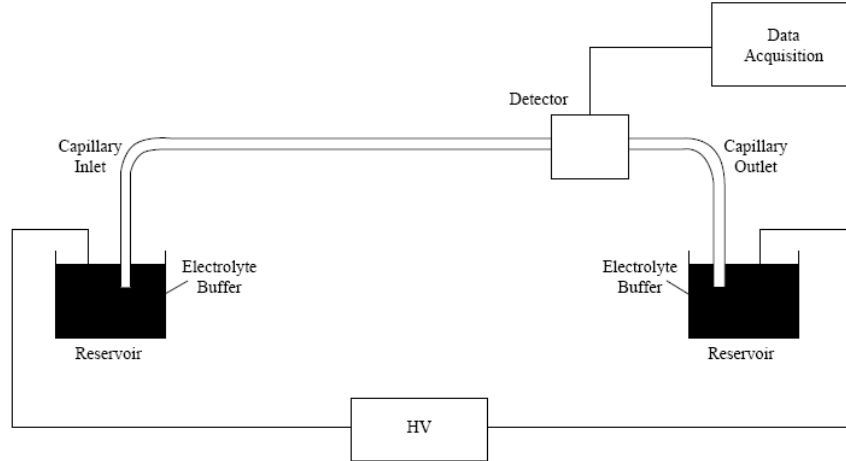
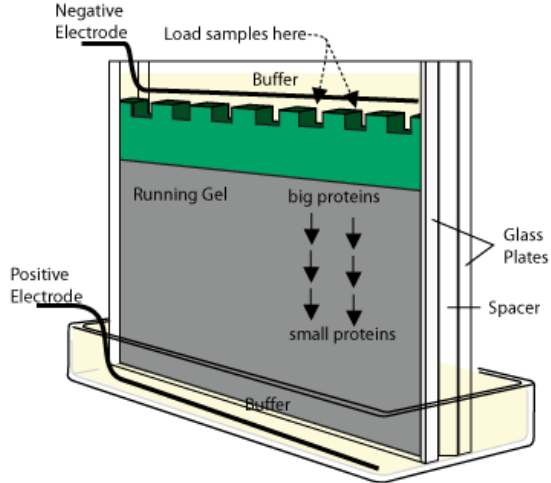

Figure 21 - Apparatus for paper electrophoresis.



Capillary zone electrophoresis set up.



SDS-PAGE electrophoresis set up.

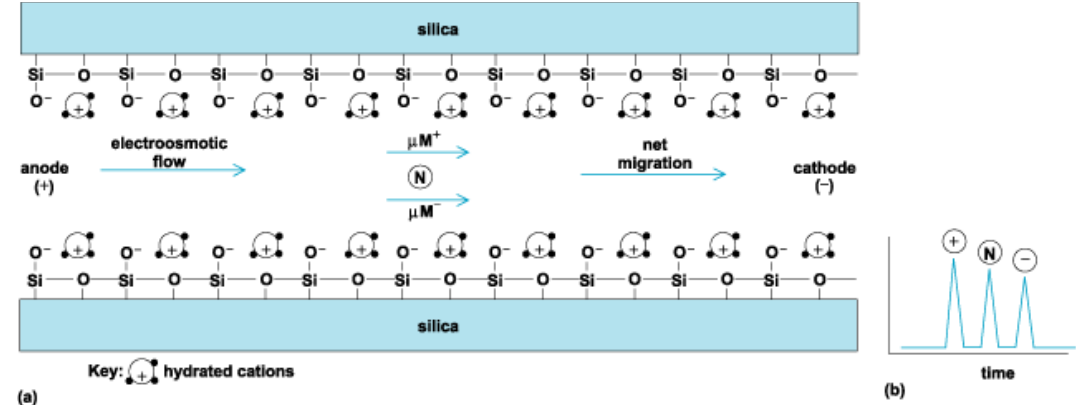

Capillary zone electrophoresis. (a) Separation mechanism showing electrophoretic mobility of the positive ion ( $\mu M^+$ ) and negative ion ( $\mu M^-$ ); N is a neutral molecule. (b) Migration order of the ions.

# Electropherogram of BSA

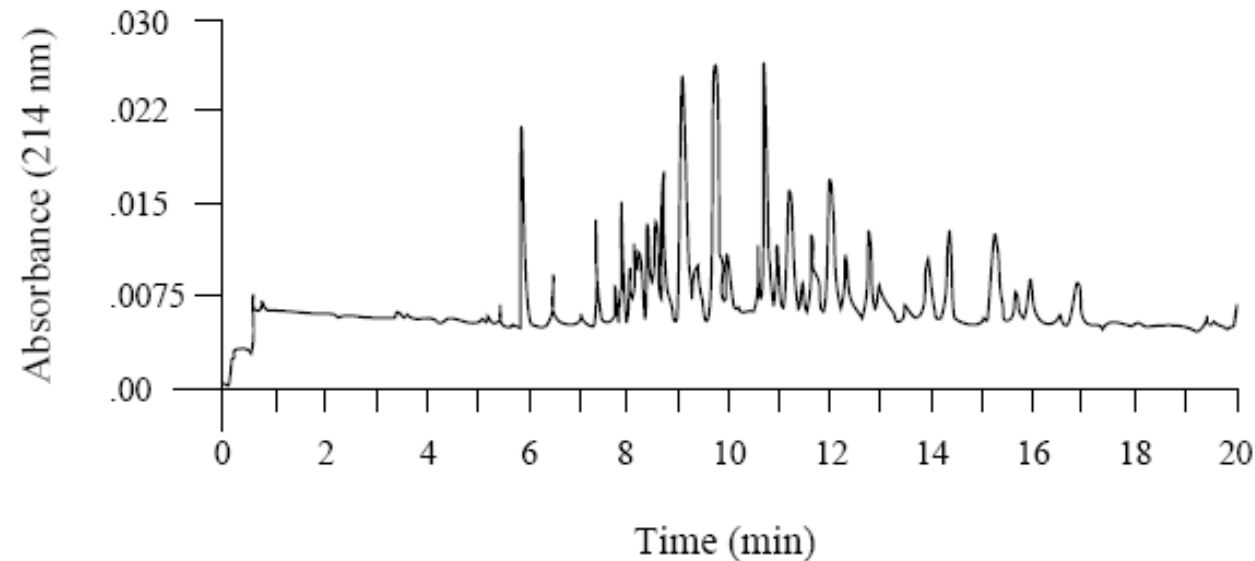

*Figure 6. CZE Separation of a Tryptic Digest of Reduced, Denatured and Alkylated Bovine Serum Albumin. Buffer, 21 mM sodium phosphate (monobasic), 1.5 M urea, pH 2.5; capillary, 59 cm. Courtesy of R. Rush, A. Cohen, and B. Karger, Northeastern University.*

The migration time ( $t_m$ ) is the time it takes a solute to move (from the beginning of the capillary to the detector window in capillary zone electrophoresis (CZE) for instance).

# Gel electrophoresis



<https://www.thermofisher.com>

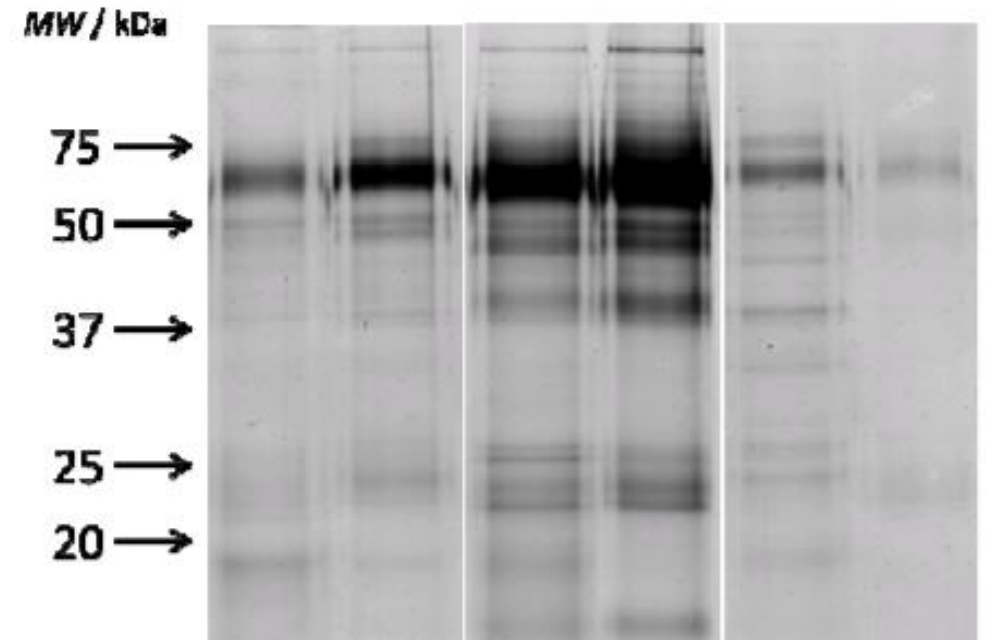

# Polyacrylamide gel polymerization

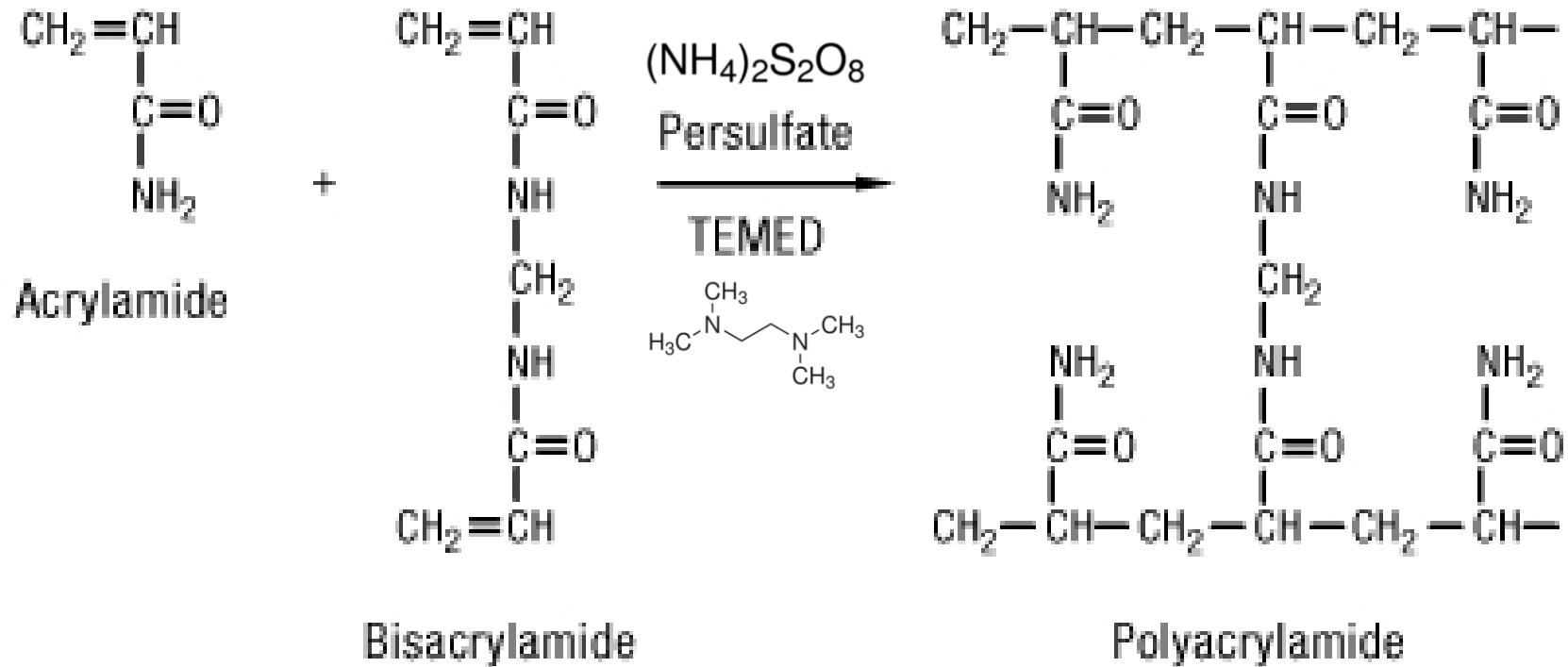

<https://www.thermofisher.com>

# Polyacrylamide gel choice/options

Protein size	Gel acrylamide percentage
4–40 kDa	20%
12–45 kDa	15%
10–70 kDa	12.5%
15–100 kDa	10%
25–200 kDa	8%

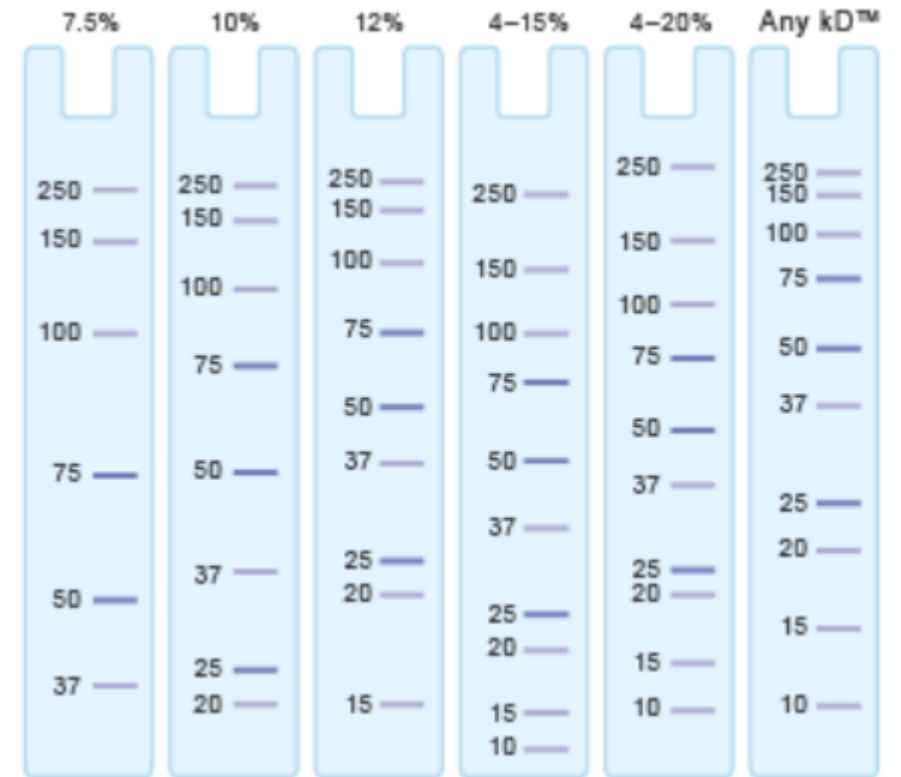

<http://www.bio-rad.com>

# 1D SDS PAGE

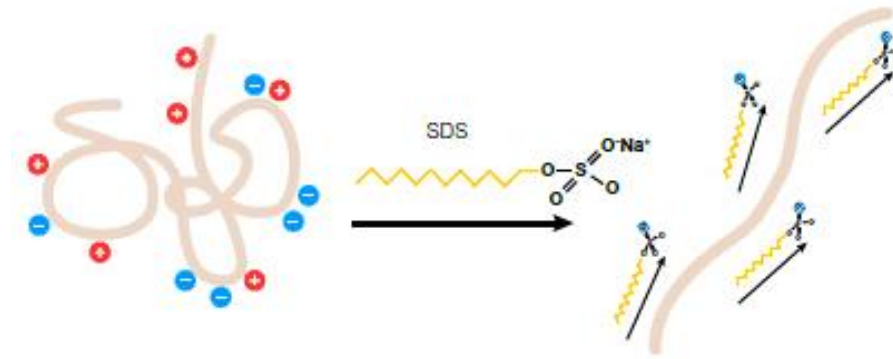

bio-rad.com

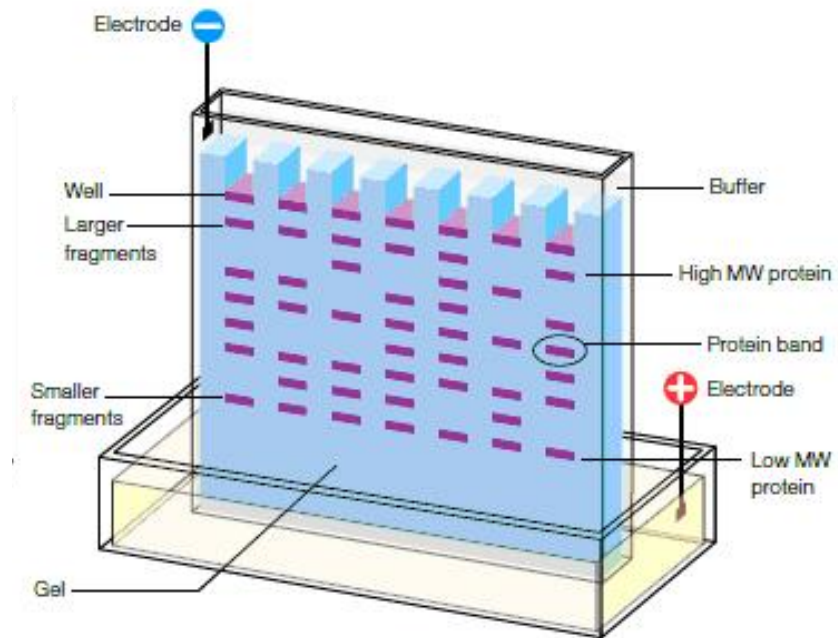

<http://www.bio-rad.com>

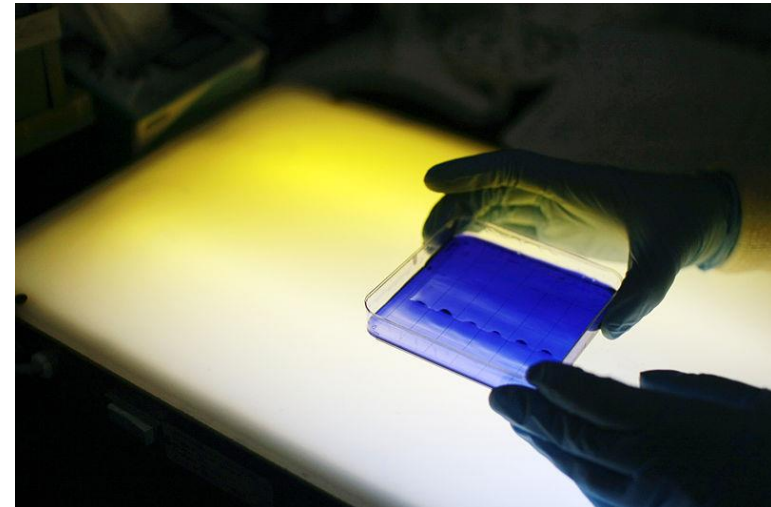

# 1D SDS PAGE with mass spectrometry

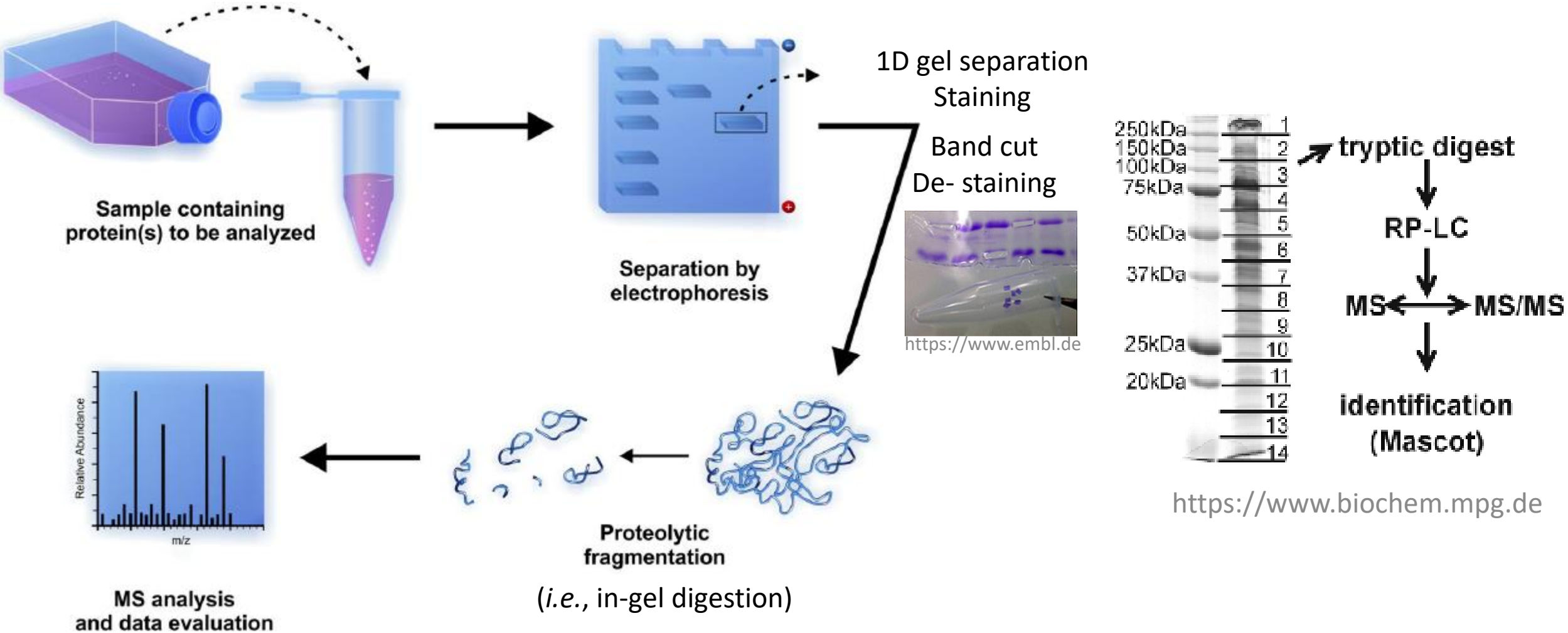

# 2. Isoelectric focusing

- **Theoretical aspects of isoelectric focusing (IEF)**
  - Amphoteric properties of amino acids, peptides, and proteins
  - Description of IEF
- **IEF protein/peptide separation for proteomics**
  - Capillary IEF (CIEF)
  - Immobilized-pH gradient (IPG) IEF
  - Electrophoretic prefractionation methods
- **Applications**
  - Peptide and protein identification
  - Post-translational modifications (PTMs)

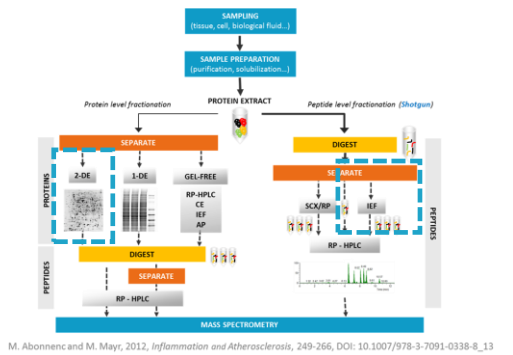

# Amino acids properties

In water, amino acids are **amphoteric**

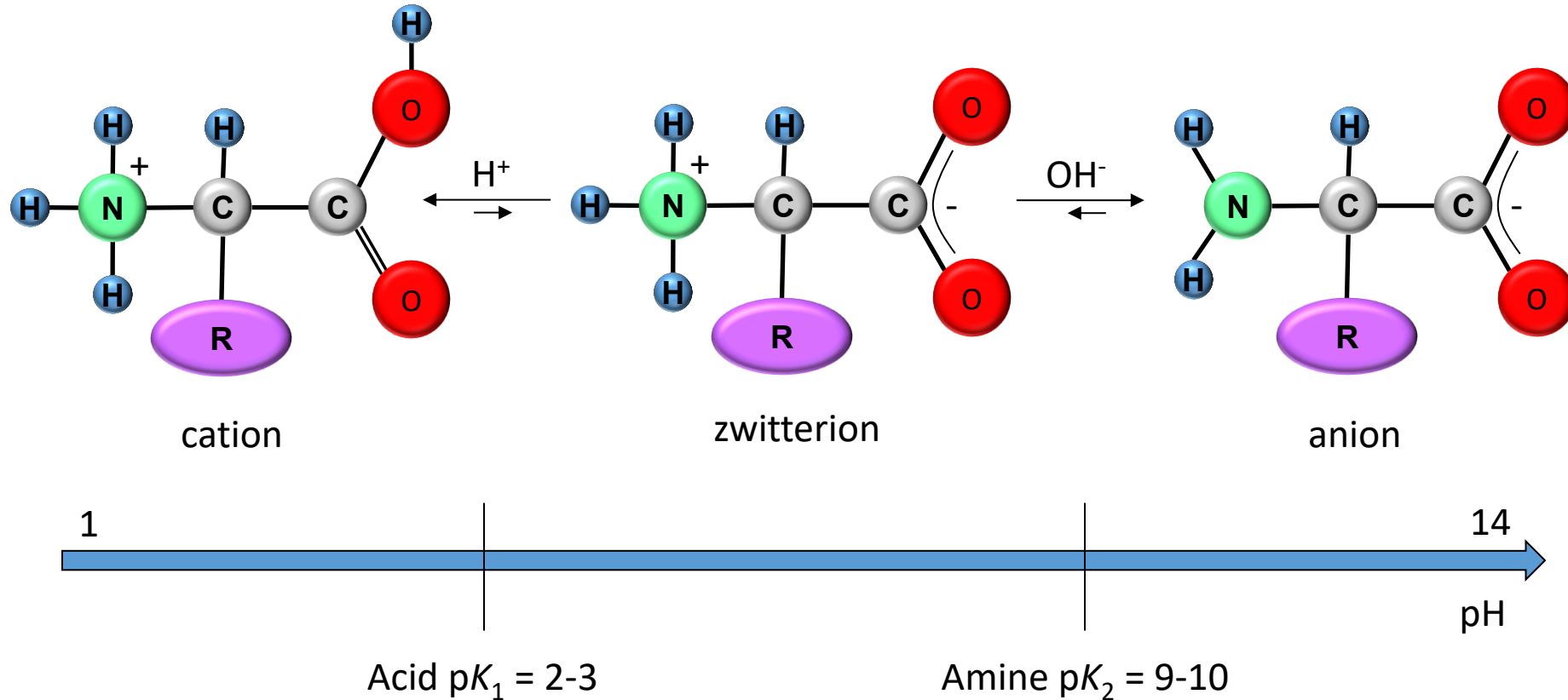

The **isoelectric point (pI)** is the pH where the molecule displays a zero net electric charge

# Positively charged lateral chains

Histidine

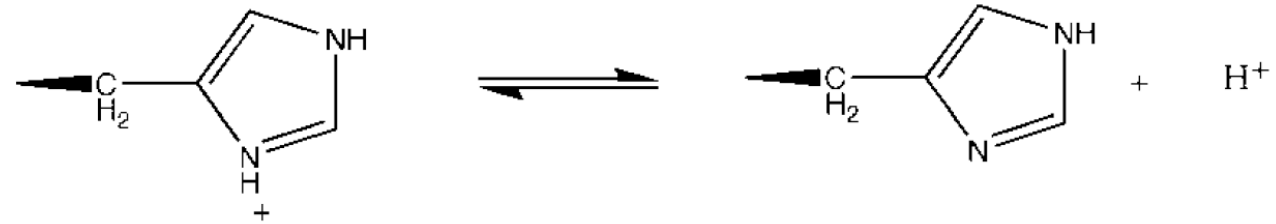

Lysine



Arginine

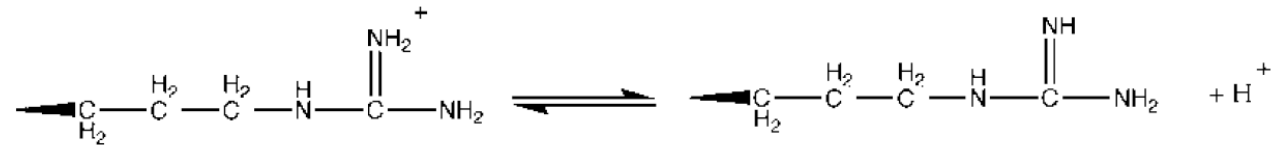

# Negatively charged lateral chains

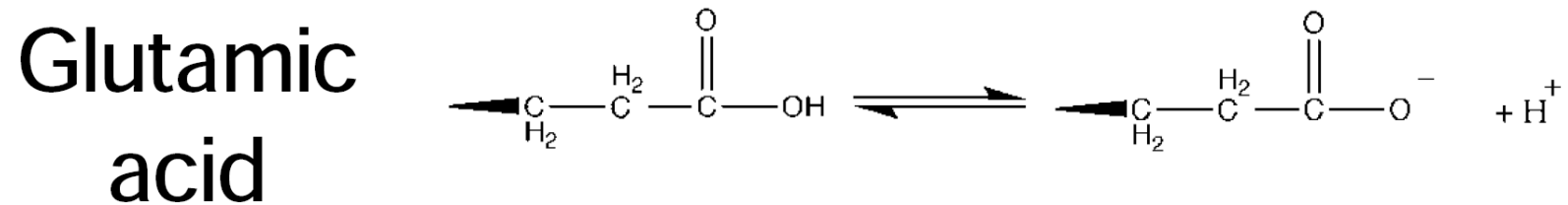
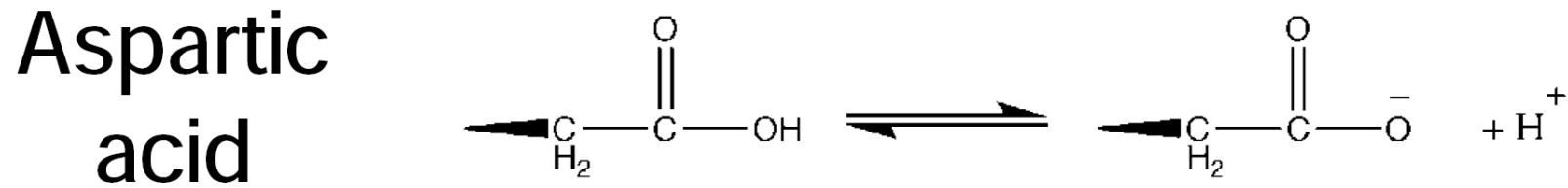
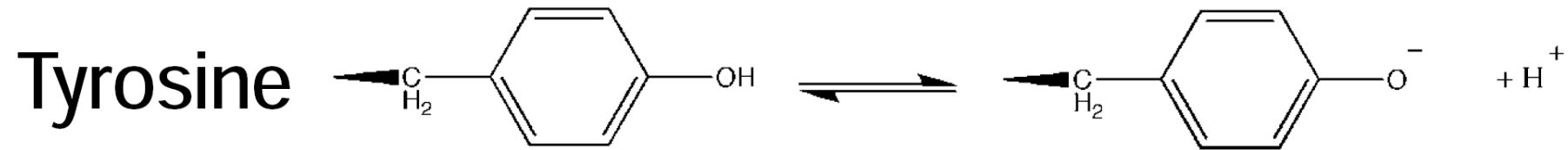

# Amino acids properties

Titration curve is the representation of the net electric charge as a function of the pH  
Basic or acidic lateral chains influence the total charges,  $pI$ , and slope at  $pI$

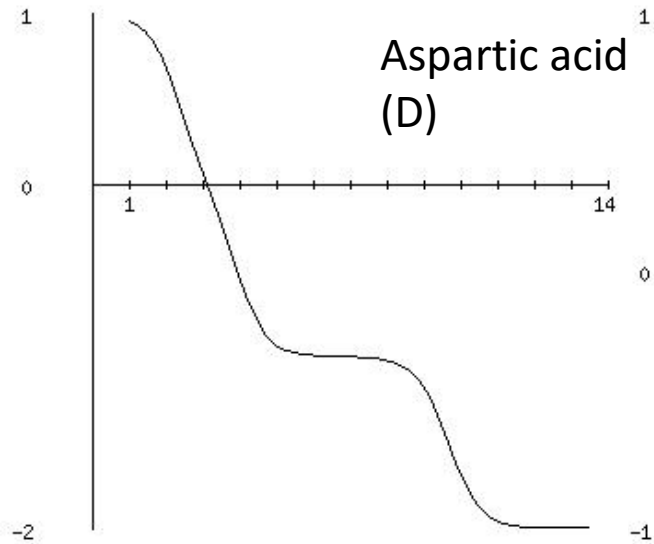

Negatively-charged lateral chains:  
cysteine, tyrosine, aspartic acid, glutamic acid

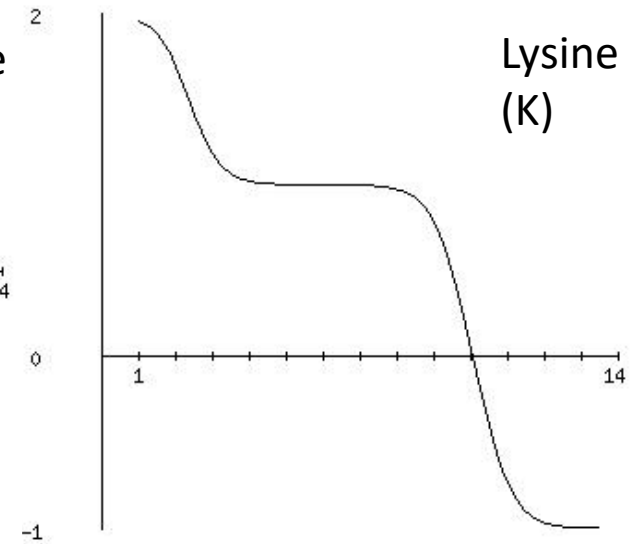
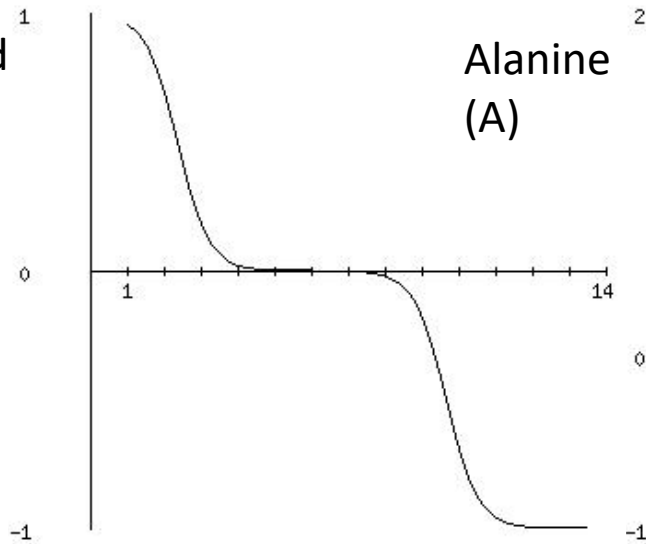

Positively-charged lateral chains:  
histidine, lysine, and arginine

# Amino acids, their pI and their pKs

Name	Code 1 letter	Code 3 letters	Molar mass (g.mol <sup>-1</sup> )	pI	pK <sub>1</sub> (-COOH)	pK <sub>2</sub> (-NH <sub>2</sub> )	pK <sub>R</sub> (-R)
Alanine	A	Ala	89.09	6.11	2.35	9.87	
Arginine	R	Arg	174.2	10.76	1.82	8.99	12.48
Asparagine	N	Asn	132.12	5.41	2.14	8.72	
Aspartic acid	D	Asp	133.1	2.85	1.99	9.9	3.9
Cysteine	C	Cys	121.16	5.05	1.92	10.7	8.18
Glutamic acid	E	Glu	147.13	3.15	2.1	9.47	4.07
Glutamine	Q	Gln	146.15	5.65	2.17	9.13	
Glycine	G	Gly	75.07	6.06	2.35	9.78	
Histidine	H	His	155.16	7.6	1.8	9.33	6.04
Isoleucine	I	Ile	131.17	6.05	2.32	9.76	
Leucine	L	Leu	131.17	6.01	2.33	9.74	
Lysine	K	Lys	146.19	9.6	2.16	9.06	10.54
Methionine	M	Met	149.21	5.74	2.13	9.28	
Phenylalanine	F	Phe	165.19	5.49	2.2	9.31	
Proline	P	Pro	115.13	6.3	1.95	10.64	
Serine	S	Ser	105.09	5.68	2.19	9.21	
Threonine	T	Thr	119.12	5.6	2.09	9.1	
Tryptophane	W	Trp	204.23	5.89	2.46	9.41	
Tyrosine	Y	Tyr	181.19	5.64	2.2	9.21	10.46
Valine	V	Val	117.15	6	2.39	9.74	

# Q1: What is the charge depending on the pH?

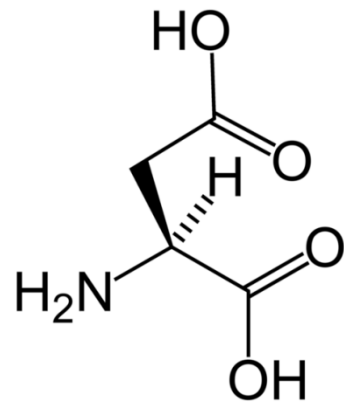

Aspartic Acid

$pK_1 = 1.99$

$pK_2 = 9.9$

$pK_R = 3.9$

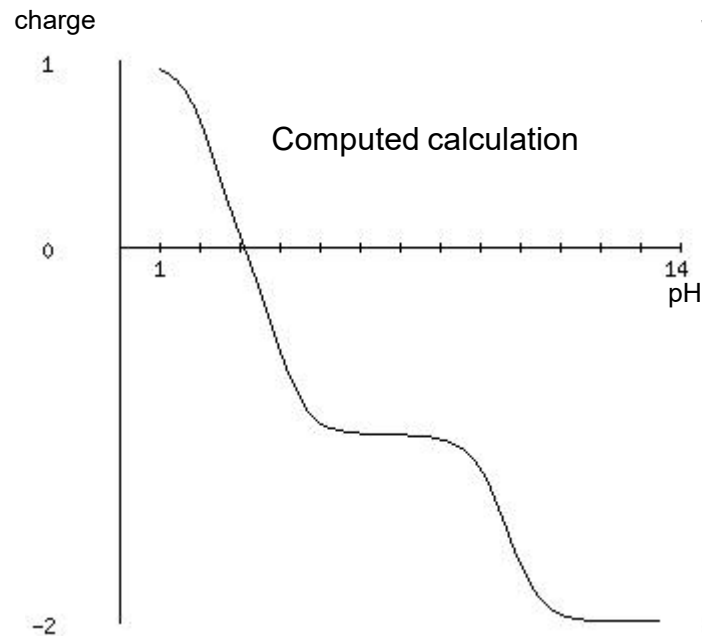

Rapid evaluation

pH	COOH (1)	NH2 (2)	COOH (R)	Total charge
1	0	+	0	+
3	-	+	0	0
5	-	+	-	-
11	-	0	-	-



$$pI \approx (pK_1 + pK_R) / 2$$

# Peptide properties

Amphoteric properties of peptides

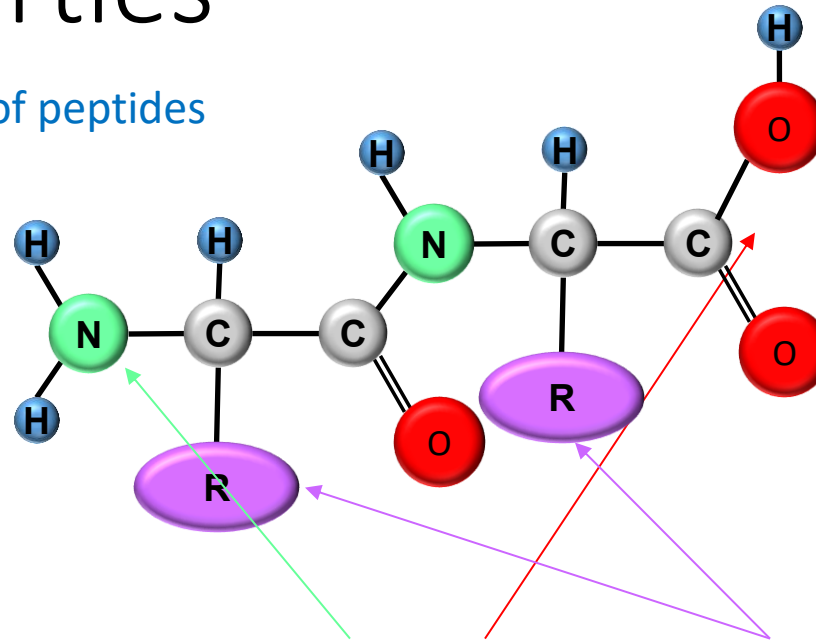

Potential charges on N-ter, C-ter, and lateral chains (R)

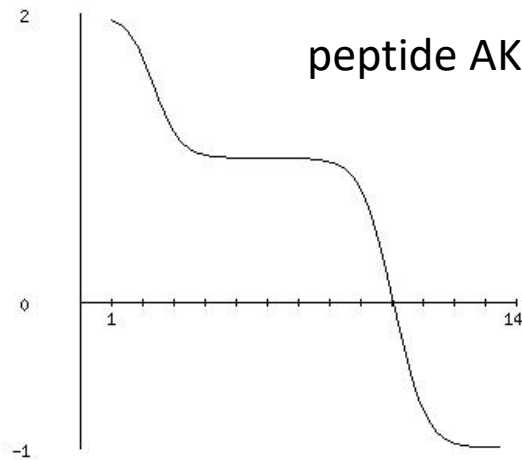

N-ter and  
basic lateral  
chain

C-ter

N-ter and  
basic lateral  
chain

C-ter and  
acidic  
lateral  
chain

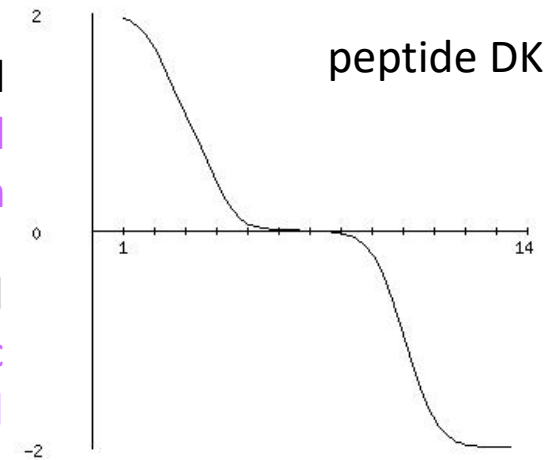

# Charge of polypeptides

The net charge of a protein containing  $i$  positively and  $j$  negatively charged groups is

$$\text{net charge} = \sum_{\text{positively charged}} \frac{n_i}{\frac{K_i}{10^{-pH}} + 1} - \sum_{\text{negatively charged}} \frac{n_j}{\frac{10^{-pH}}{K_j} + 1}$$

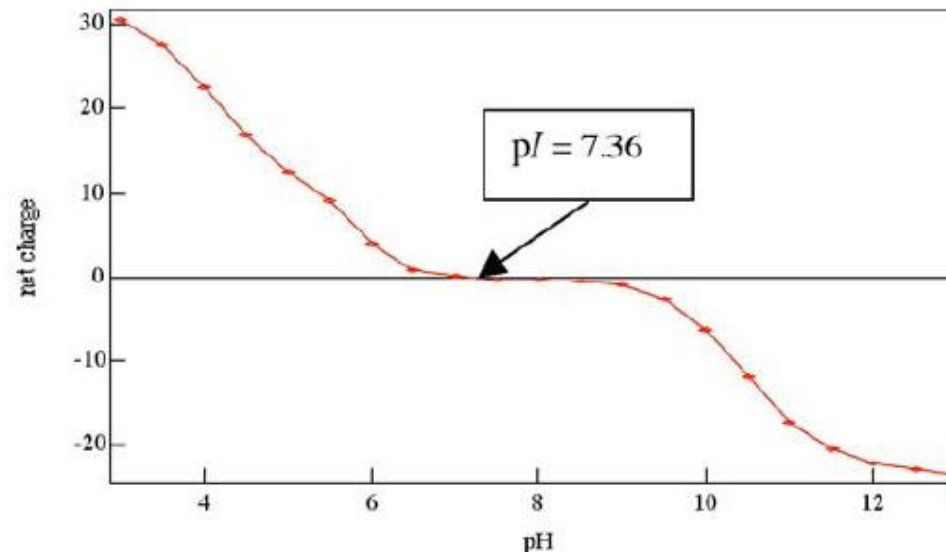

Net charge versus pH for horse heart myoglobin

# Effect of charge and pH

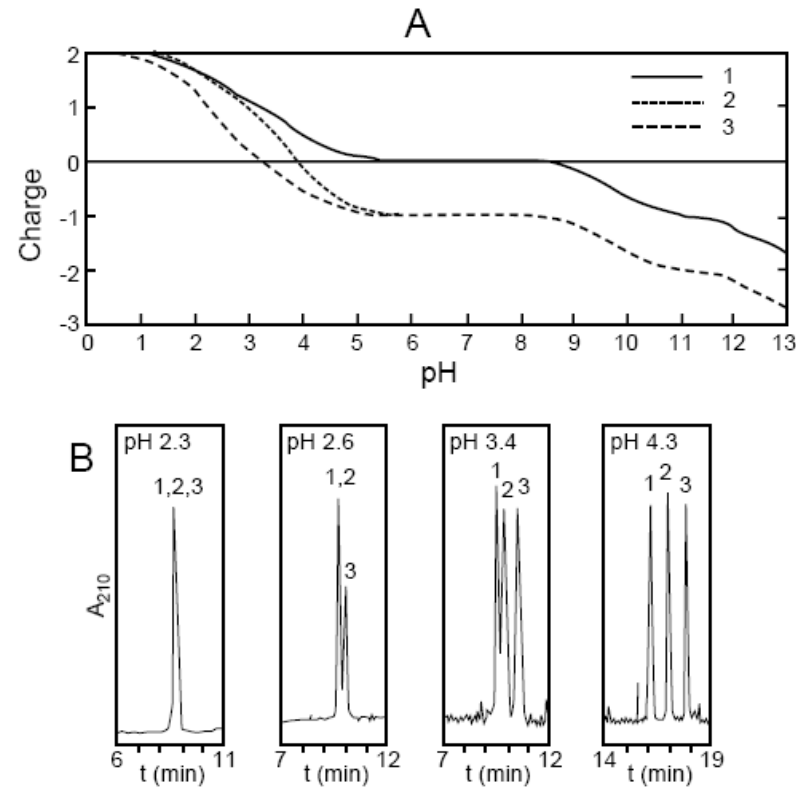

**Figure 1-3.** (A) Calculated charge versus pH profiles and (B) electropherograms at varying pH for the synthetic model peptides ( $\text{Leu}^{27}, \text{Asn}^{28}$ )-GRF(22-32)-OH, 2, and ( $\text{Leu}^{27}, \beta\text{-Asp}^{28}$ )-GRF(22-32)-OH, 3. The pH of the 25-mM  $\text{Na}_2\text{HPO}_4/\text{H}_3\text{PO}_4$  running buffer is shown in the upper left corner of each panel. Reprinted with permission from Bongers et al., *J. Liq. Chromatogr.* 15, 1115 (1992).

# Isoelectric focusing (IEF)

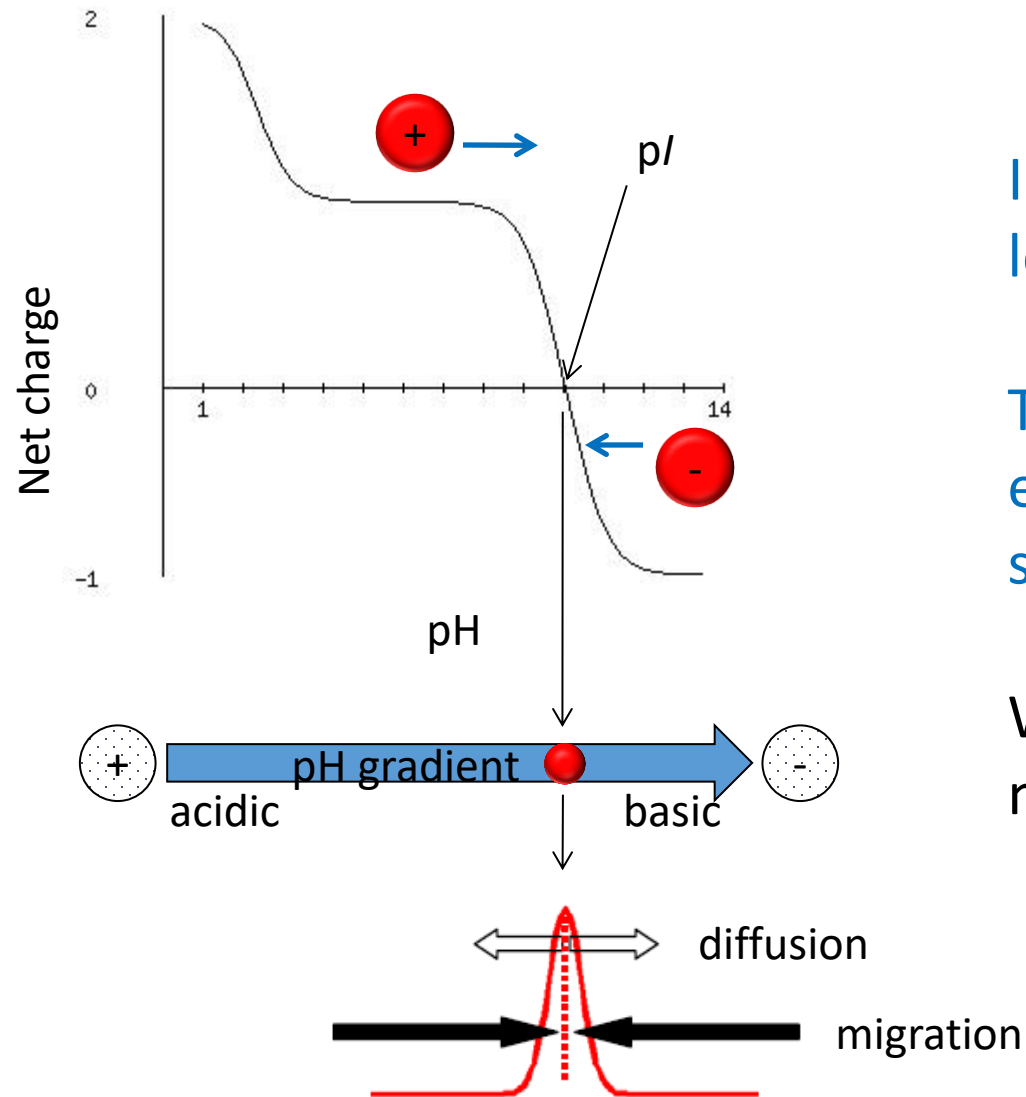

IEF is run in a pH gradient where the pH is low at the anode and high at the cathode

The analyte will migrate so long as its net electric charge is not zero to reach a steady-state position

When the analyte is at pI, it will stop migrating in the electric field

# Generation of pH gradient

To separate biomolecules in a highly resolved and reproducible way, the pH gradient generated in IEF should be **time stable** with a **constant conductivity and buffer capacity**

Two ways:

- pH gradients formed in the electric field by amphoteric buffers, the **carrier ampholytes (CA)**

With 2 fundamental properties of CA:

- to be amphoteric so that they could also reach a steady state position during the separation
- to be “carrier” of the current (a good conducting species) and of the pH (a good buffering species)

- **immobilized pH gradients**, in which the buffering groups are part of the gel

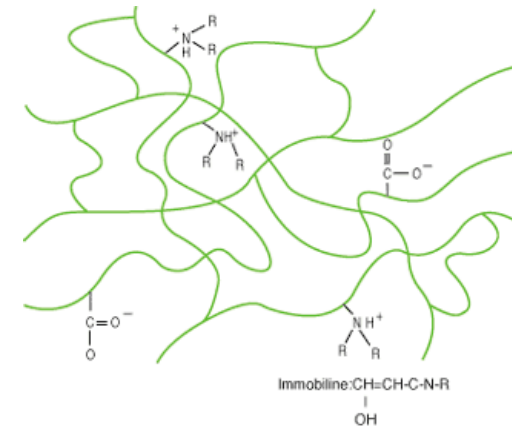

Copyright © 2010 General Electric Company

# Carrier ampholytes (CA)

## CA: Ampholines™

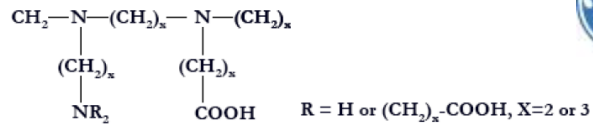

## CA: Pharmalyte™

Pharmalyte™ carrier ampholytes, prepared by the co-polymerization of glycine, glycyglycine, amines, and epichlorohydrin, are available in five broad-range and four narrow-range pH intervals. Each interval contains numerous ampholytes with a high buffering capacity per pH unit. Pharmalyte™ carrier ampholytes form an extremely stable linear pH gradient exhibiting even conductivity across the gel.

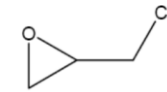

Epichlorohydrin

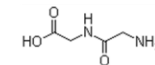

glycyglycine

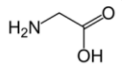

glycine

## CA: Servalyt™



SERVALYT™ ampholytes are a mixture of synthetically derived species of average molecular weight distribution from 400 to 1000 dalton

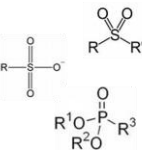
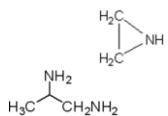

## CA: Bio-Lyte®

Not much information available...



- Bio-Lyte 3/10 Ampholyte
- Bio-Lyte 4/6 Ampholyte
- Bio-Lyte 5/7 Ampholyte
- Bio-Lyte 6/8 Ampholyte
- Bio-Lyte 5/8 Ampholyte
- Bio-Lyte 3/5 Ampholyte
- Bio-Lyte 7/9 Ampholyte
- Bio-Lyte 8/10 Ampholyte

# CA properties

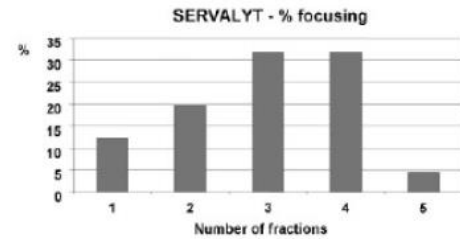
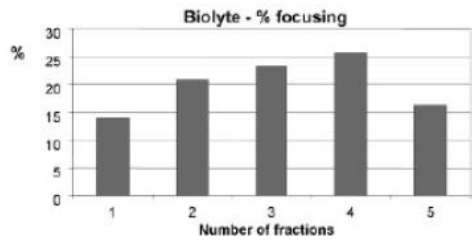
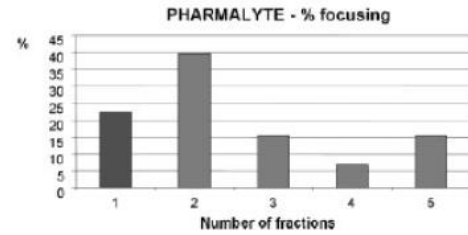
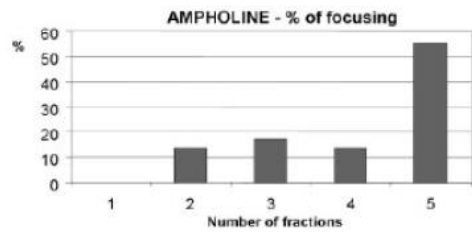

*Electrophoresis 2006, 27, 3919–3934*

Percentage of species focusing in either a single fraction (1) or over the entire pH gradient (5)

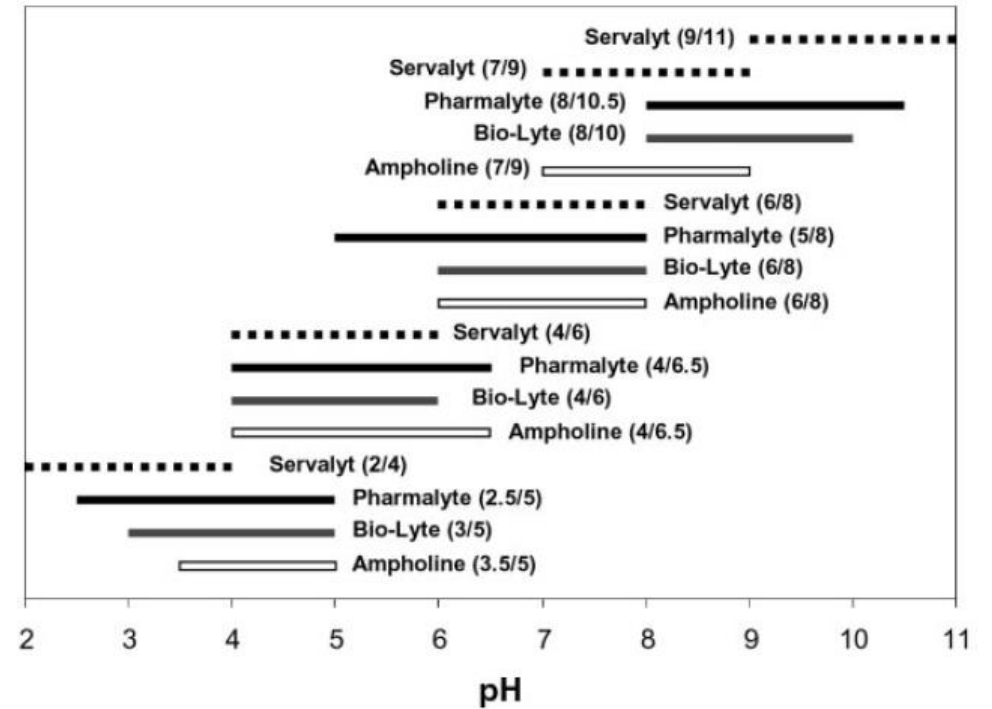

*Electrophoresis 2007, 28, 3799–3810*

*Electrophoresis 2006, 27, 4849–4858, Electrophoresis 2007, 28, 715–723, Electrophoresis 2007, 28, 1488–1494, Electrophoresis 2007, 28, 3156–3162*

# Immobilized pH gradient (IPG) gels

The **Immobilines™** are acrylamide derivatives with the general chemical formula:

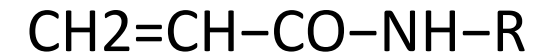

where R contains either a carboxylic acid (pK 3.6, 4.4 and 4.6) or an amino group (pK 6.2, 7.0, 8.5 and 9.3) incorporated in the polyacrylamide gel during polymerization

their concentrations and dissociation constants defined the pH

their incorporation amount and their buffer capacity act on the conductivity of the gel

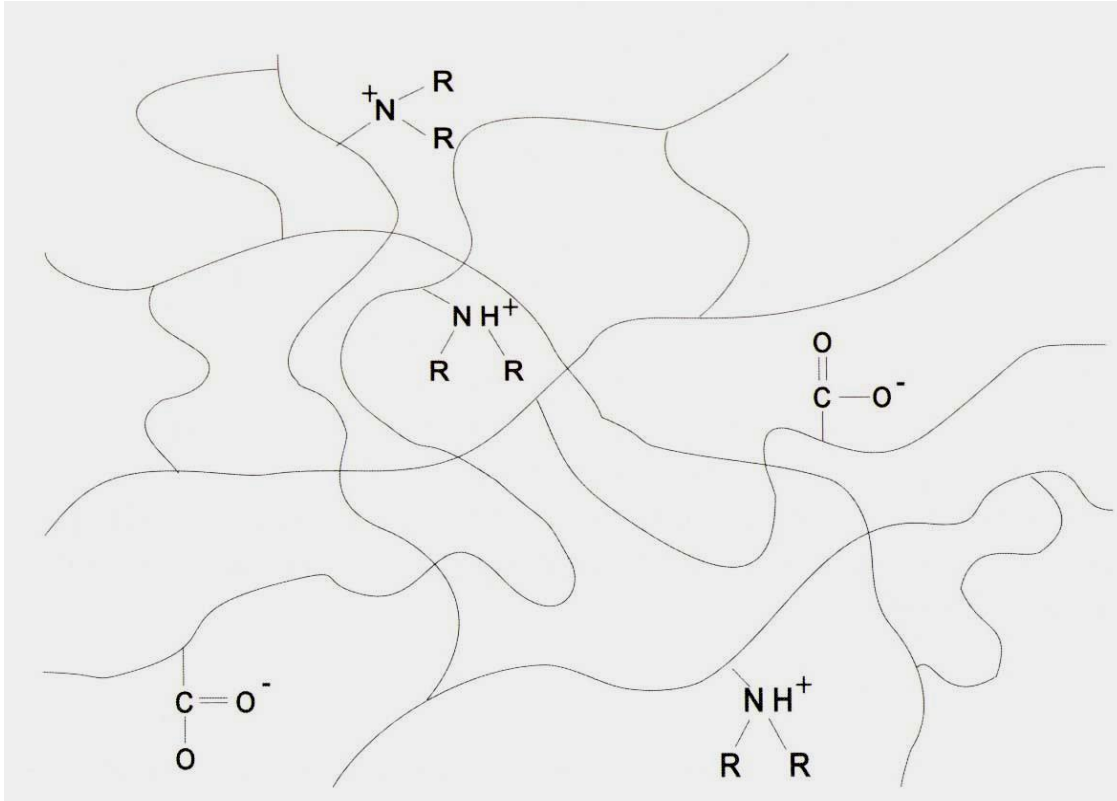

Electrophoresis in Practice, Reiner Westermeier, 1997, Second Edition, VCH, Weinheim

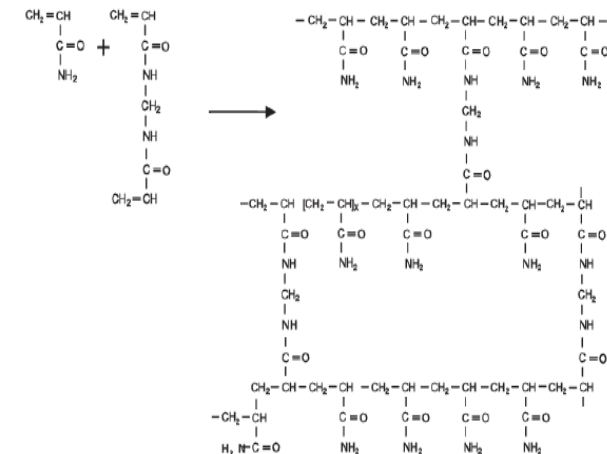

Polymerization reaction of acrylamide and methylenebisacrylamide

# Immobilized pH gradient (IPG) gels

To be able to buffer at a precise pH value, at least two different Immobilines are necessary, an acid and a base

A pH gradient is obtained by continuous change in the ratio of Immobilines. The principle is that of an acid base titration and the pH value at each stage is defined by the Henderson-Hasselbalch equation:

$$\text{pH} = \text{p}K_{\text{B}} + \log \frac{C_{\text{B}} - C_{\text{A}}}{C_{\text{A}}}$$

when the buffering Immobiline is a base.

$$\text{pH} = \text{p}K_{\text{A}} + \log \frac{C_{\text{B}}}{C_{\text{A}} - C_{\text{B}}}$$

when the buffering Immobiline is an acid.

$C_{\text{A}}$  and  $C_{\text{B}}$  are the molar concentration of the acid, and basic Immobiline

# Immobilines™ and IPG gel preparation

Available Immobilines™ allow the generation of any narrow pH gradient between pH 3 and 10

	H <sub>2</sub> O		Polyacrylamide gel T% = 5%, C% = 3%		Polyacrylamide gel T% = 5%, C% = 3% glycerol 25% (w/v)	
	10°C	25°C	10°C	25°C	10°C	25°C
<b>Acid</b>						
Immobiline p <i>K</i> 3.6	3.57	3.58	-	-	3.68 ± 0.02	3.75 ± 0.02
Immobiline p <i>K</i> 4.4	4.39	4.39	4.30 ± 0.02	4.36 ± 0.02	4.40 ± 0.03	4.47 ± 0.03
Immobiline p <i>K</i> 4.6	4.60	4.61	4.51 ± 0.02	4.61 ± 0.02	4.61 ± 0.02	4.71 ± 0.03
<b>Base</b>						
Immobiline p <i>K</i> 6.2	6.41	6.23	6.21 ± 0.05	6.15 ± 0.03	6.32 ± 0.08	6.24 ± 0.07
Immobiline p <i>K</i> 7.0	7.12	6.97	7.06 ± 0.07	6.96 ± 0.05	7.08 ± 0.07	6.95 ± 0.06
Immobiline p <i>K</i> 8.5	8.96	8.53	8.50 ± 0.06	8.38 ± 0.06	8.66 ± 0.09	8.45 ± 0.07
Immobiline p <i>K</i> 9.3	9.64	9.28	9.59 ± 0.08	9.31 ± 0.07	9.57 ± 0.06	9.30 ± 0.05

T is the total acrylamide concentration and C is the degree of cross-linking

But we buy them commercial...

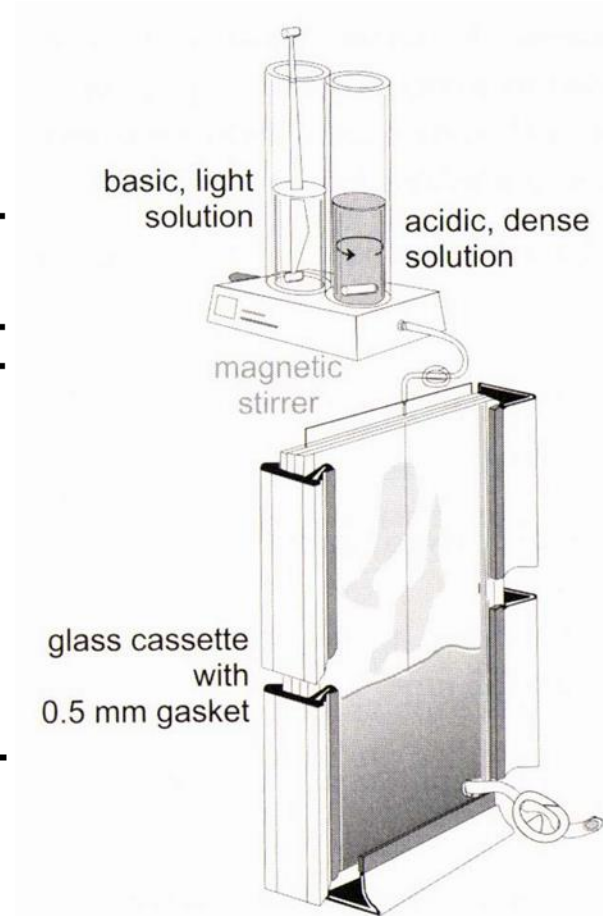

Immobiline = 0.2 M

Acidic solution is usually made denser by adding glycerol so that the layers in the molds do not mix.

The mixing of the less dense dilute solution with the viscous solution takes place in the mixing chamber using a magnetic stirrer bar.

The gel is usually 0.5 mm thick

# IEF peptide separation for proteomics: Capillary IEF (CIEF)

Separation carried out in capillaries:

- Limited convection because small cross-section, electric power and heating
- **Resolution** to 0.01 pI units
- **Concentration** of analytes by a factor of 2 or 3 orders of magnitude
- Rapid focusing (min range)

No widespread use in proteomics because:

- Presence of **carrier ampholytes** (UV and MS)
- Need for pI markers to estimate the pI
- Low **loading** achievable in capillary electrophoresis and precipitation

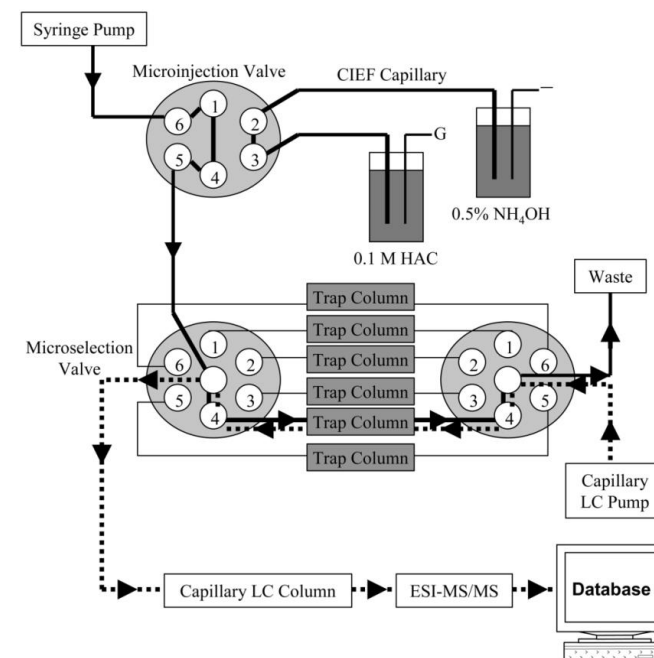
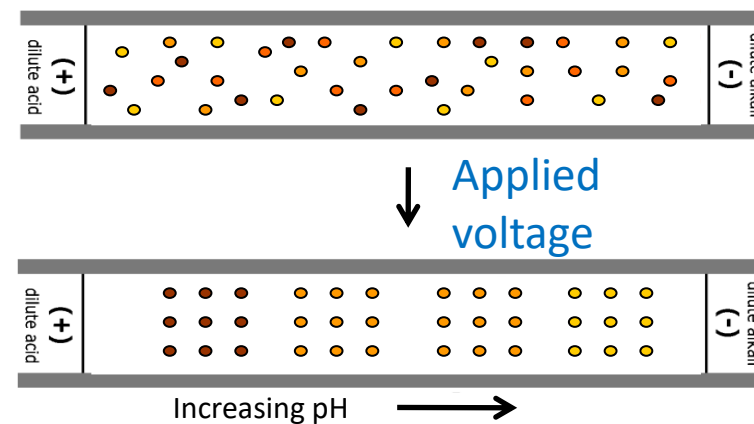

Copyright © 2003 American Chemical Society

*Kašička, Electrophoresis. 2008, 29, 179-206*

*Simpson & Smith, Electrophoresis. 2005, 29, 1291-1305*

*Shimura et al., Anal.Chem. 2000, 4747-4757*

*Shen et al., Anal. Chem. 2000, 72, 2154-2159*

*Chen et al., Anal. Chem. 2003, 75, 3145-3152*

# IEF peptide separation for proteomics: Capillary IEF (CIEF)

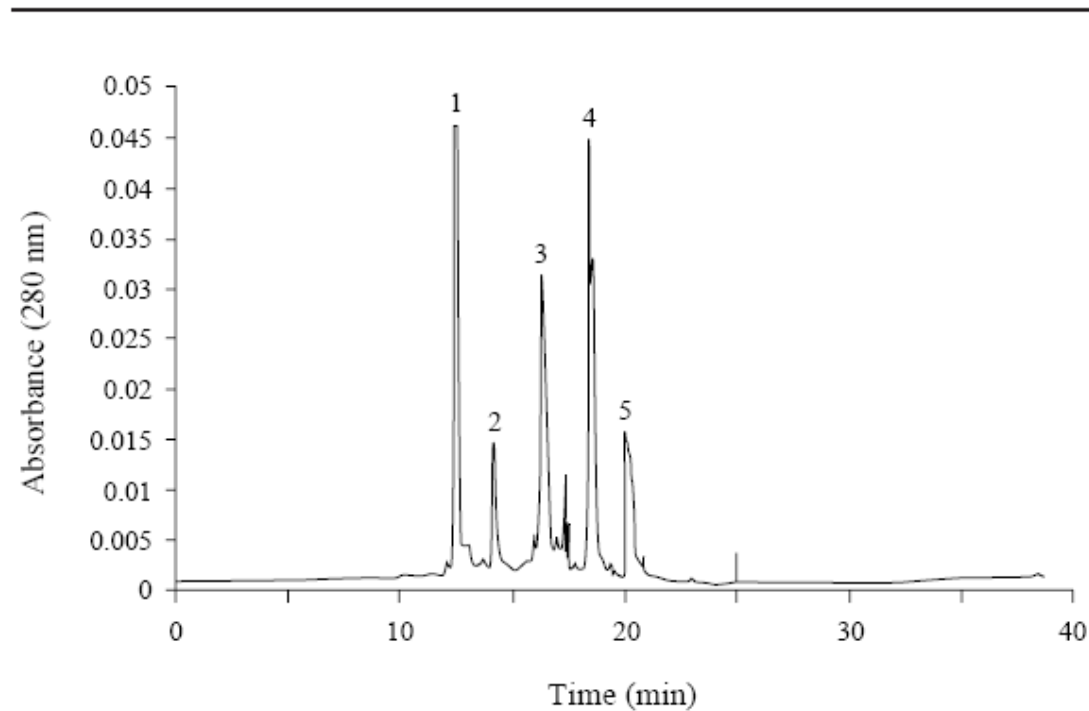

*Figure 8. Separation of a Protein Mixture by IEF. Ampholyte pH range, 3.5-10; catholyte, 50 mM sodium hydroxide; analyte, 150 mM phosphoric acid; voltage, 25 kV; mobilization (catholyte), 50 mM sodium chloride, 50 mM sodium hydroxide. Courtesy of R. Nelson and B. Karger, Northeastern University.*

# IEF peptide separation for proteomics: IPG IEF, first dimension of protein 2D-PAGE

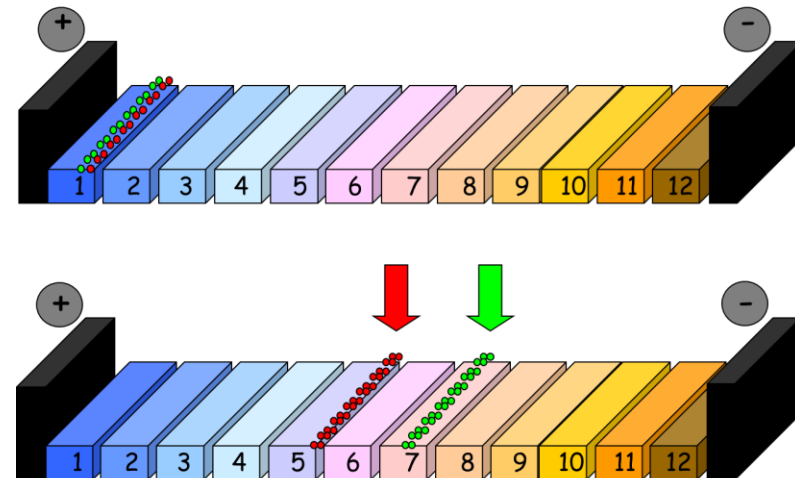
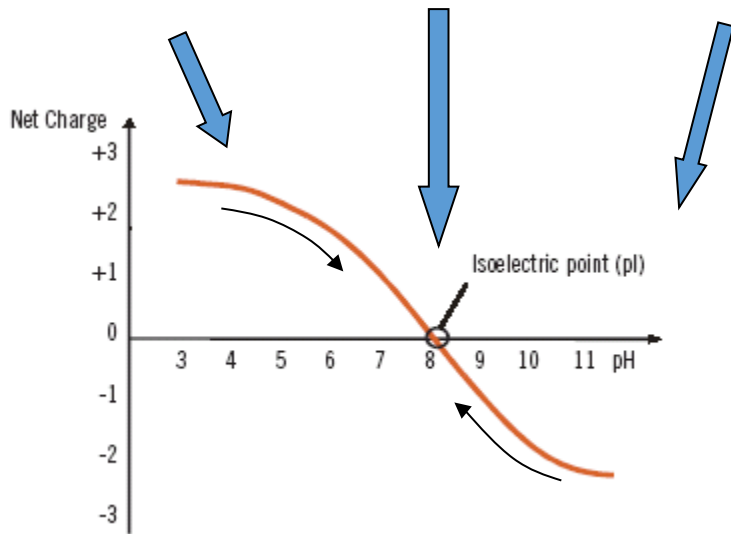
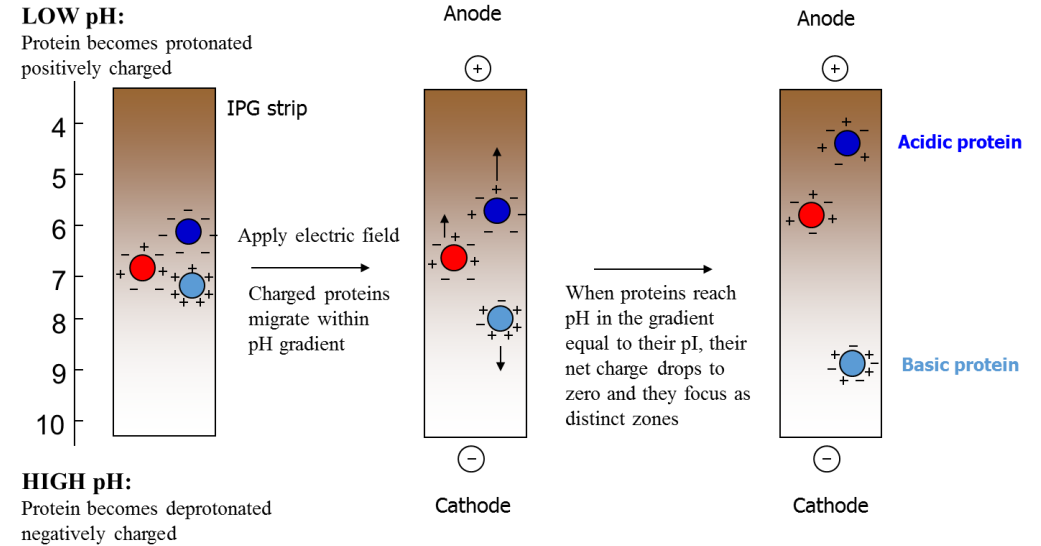
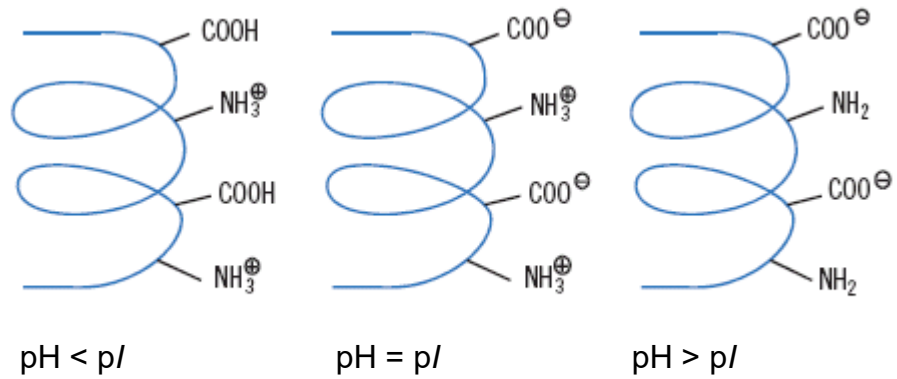

# IPG IEF in the lab (1)

IEF performed with IPG strips

## Dry IPG strip

pH gradient immobilized in polyacrylamide gel 5 %T, plastic backing  
IPG strips home-made or commercial  
Different strip length and pH ranges available

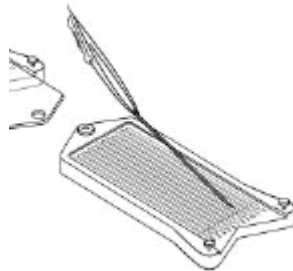

### Strip rehydration

e.g. Strip length. 18 cm,  
450 ul of rehydration  
solution

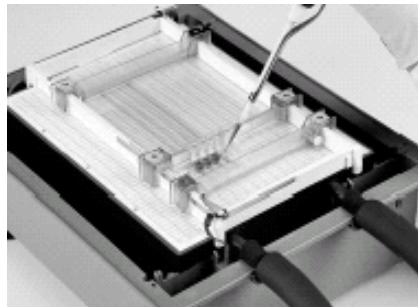

### Sample application via sample cups

e.g. Strip length. 18 cm,  
load 60ug of protein,  
maximal volume 100 ul  
(ideal for concentrated  
sample and plasma)-  
Cathode loading

### Strip rehydration and sample application

e.g. Strip length. 18 cm,  
load 60ug of protein,  
maximal volume 450 ul  
(ideal for diluted samples)

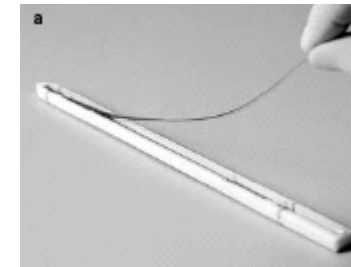
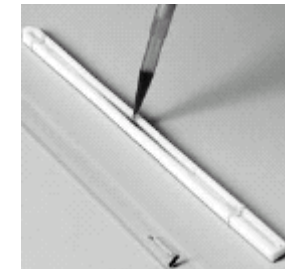

From handbook 2-D Electrophoresis,  
Principles and Methods, Amersham Biosciences

# IPG IEF in the lab (2)

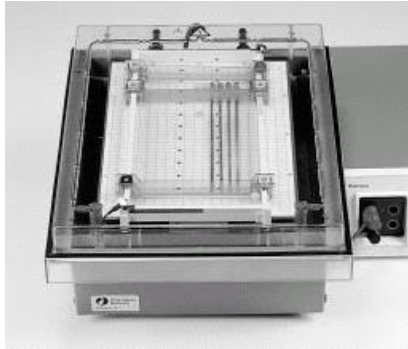

Multiphor II

## Migration in electric field

e.g. Entry phase 300 V,  
stepwise increase up to 5000 V  
In total ~100 kVh  
duration ~ 8 h  
constant temperature 15 °C



IPGphor

From handbook 2-D Electrophoresis,  
Principles and Methods, Amersham Biosciences

## IPG strips, silver stained

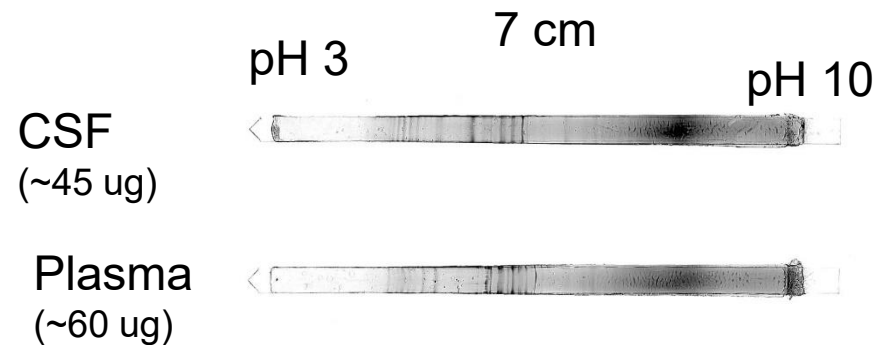

# 2D electrophoresis

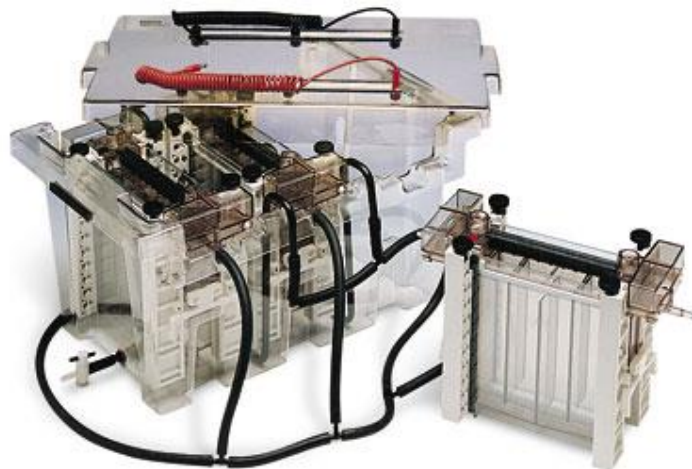
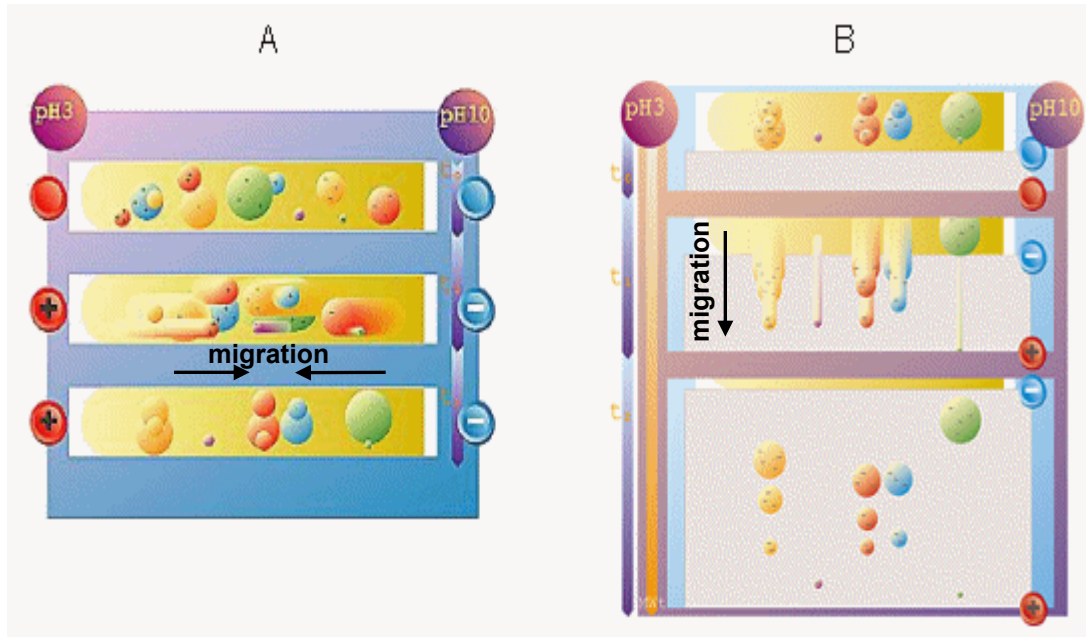

*MW*

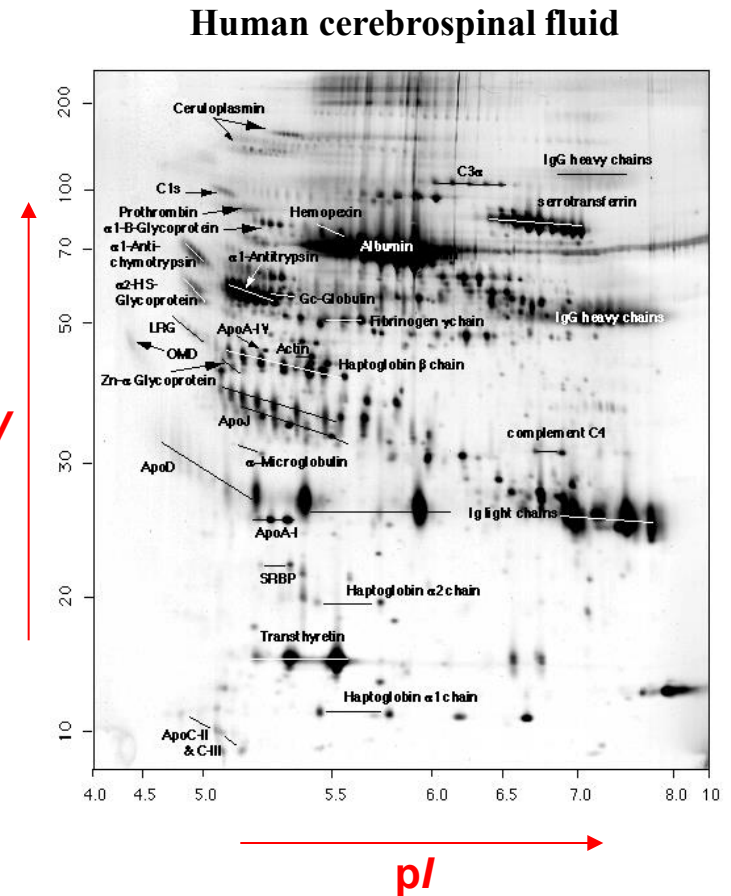

# Example of prostaglandin D2 synthase in CSF

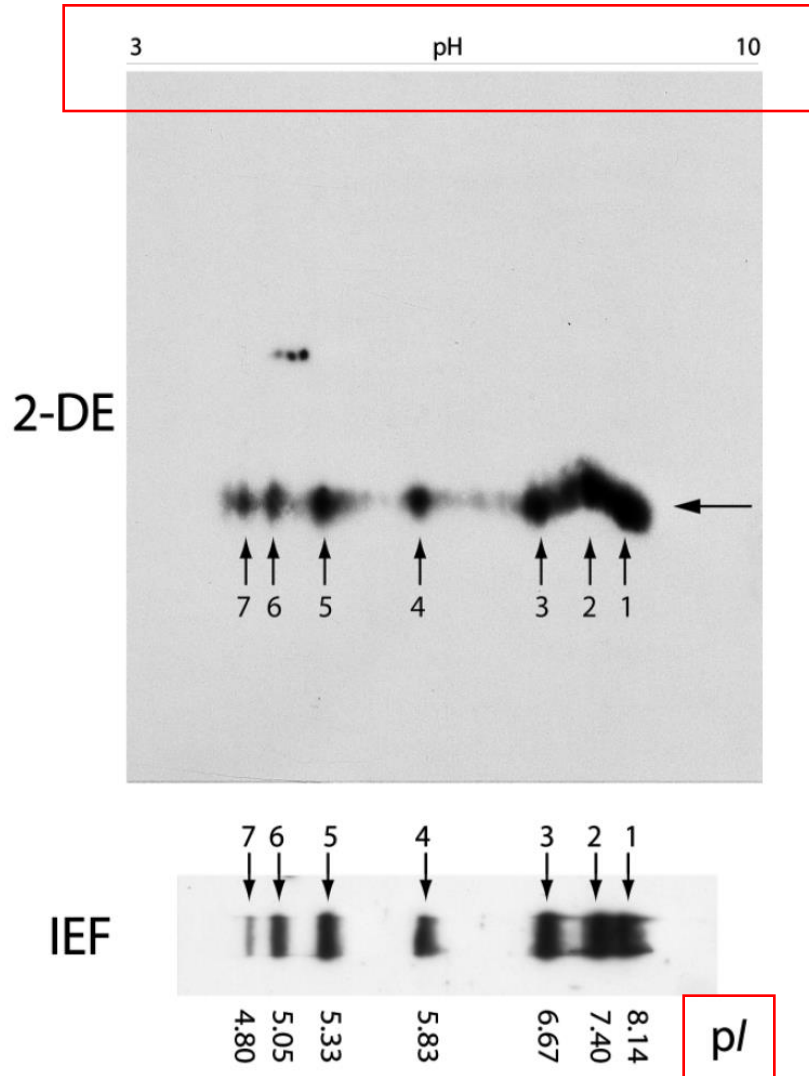

## Separation of isoforms

Figure. Comparison of prostaglandin D2 synthase (PGDS) posttranslational modification (PTM) patterns obtained with 2-DE- and IEF-immunoblotting techniques. Fortyfive micrograms of protein was loaded on an IPG strip (pH 3–10 NL, 7 cm) in the 2-DE method. SDS-PAGE dimension was performed on a 12% T vertical gel. Proteins were electroblotted onto a PVDF membrane. Two micrograms of protein was loaded on an IPG strip (pH 3–10 NL, 7 cm) in the IEF method. Proteins were transferred onto a PVDF membrane by passive diffusion. Human PGDS isoforms were detected with a rabbit polyclonal antibody and ECL reagents

**The PTM changes, characterized by a shift from acidic to more basic isoforms, are most probably related to a deglycosylation process**

# Electrophoretic prefractionation methods

- Rotofor
- IsoPrime
- ZOOM IEF fractionator
- Free flow electrophoresis (FFE)
- **Shotgun IEF**
- **OFFGEL electrophoresis (OGE)**



Copyright © 2011 Life Technologies

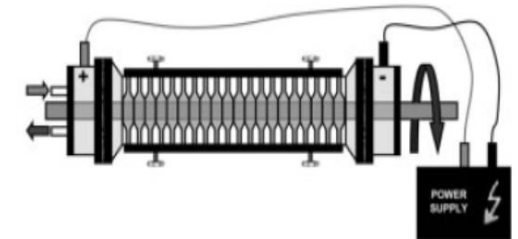
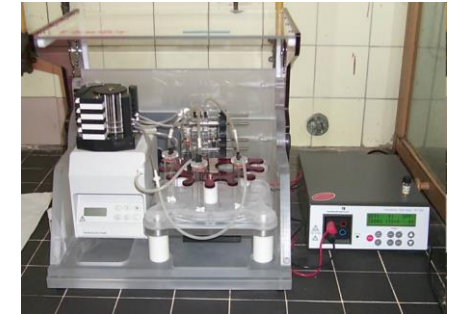

Righetti, *Electrophoresis* 2007, 28, 3799–3810

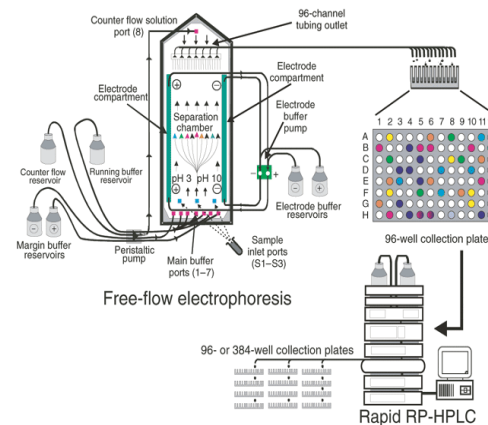

Moritz and Simpson, *Nature Methods* 2005, 2, 863 - 873

Copyright © 2005 Nature Publishing Group



Copyright © 2011 Bio-Rad Laboratories, Inc.

# Immobilized pH gradient (IPG) shotgun IEF

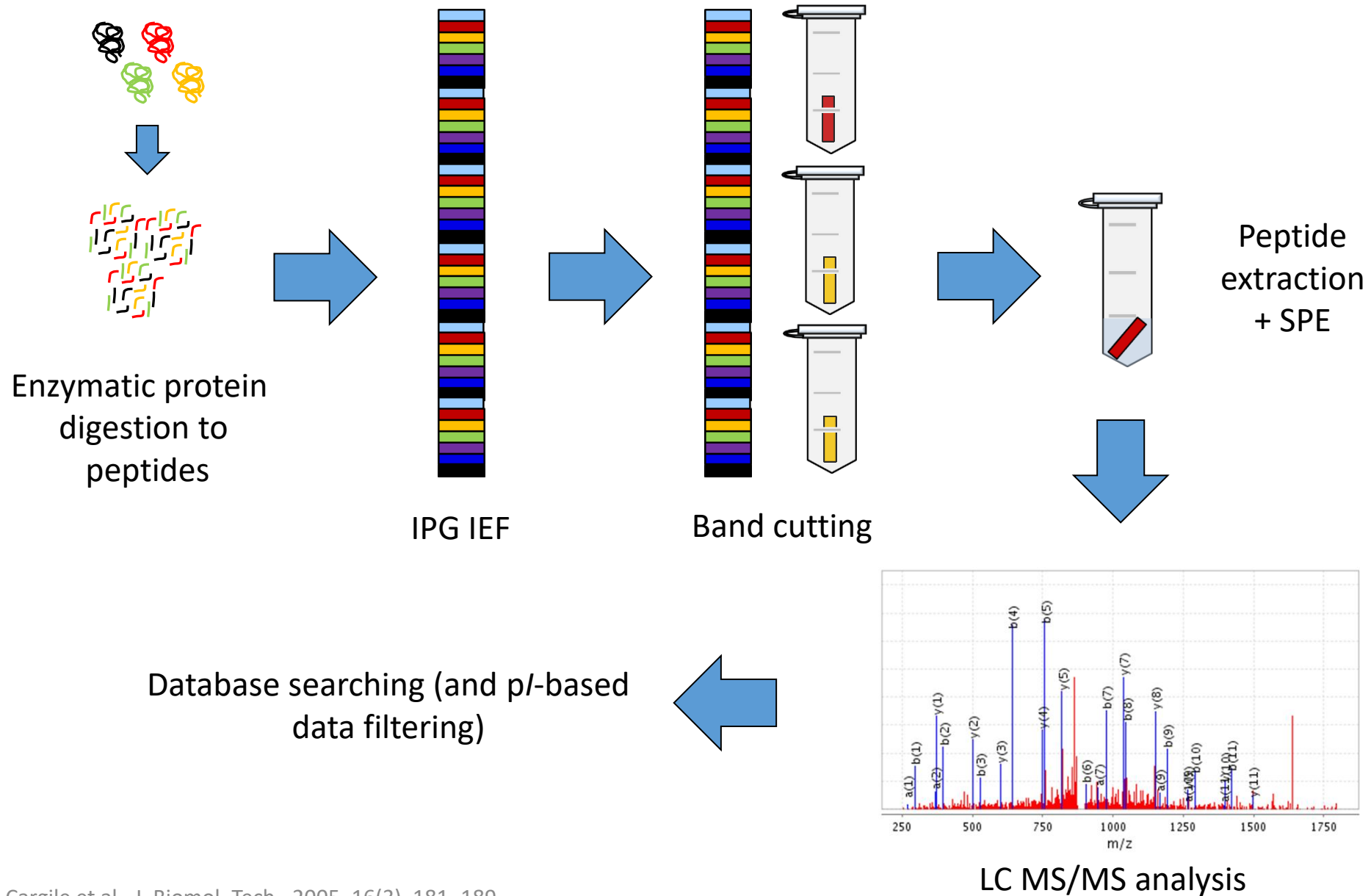

# Separation efficiency

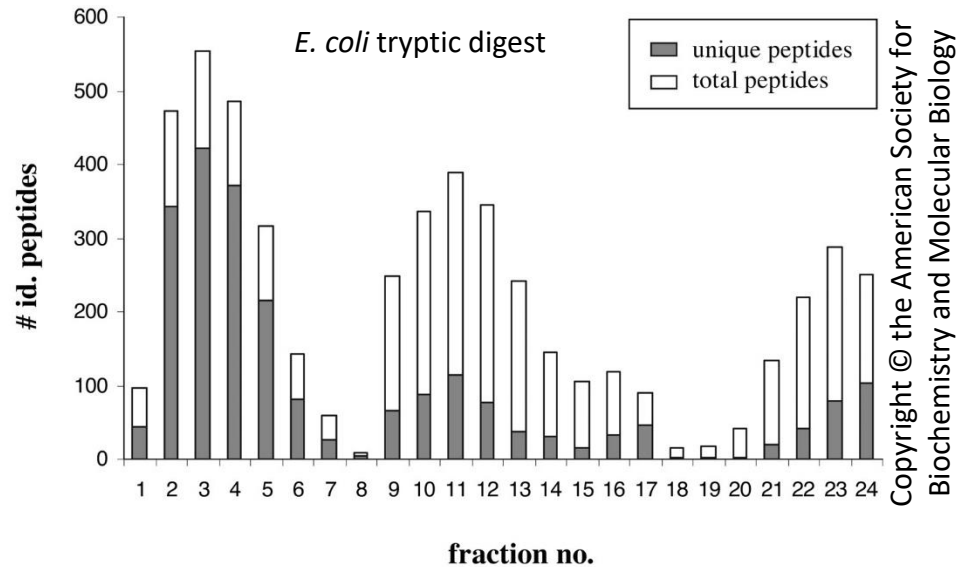

Horth et al., Mol. Cell. Proteomics 2006, 5, 1968-1974

- Good **reproducibility** of IPG gels
- High **resolving power** (steep slope between fraction and uniqueness)
- High **loading capacity** (0.1-1 mg)

log scale

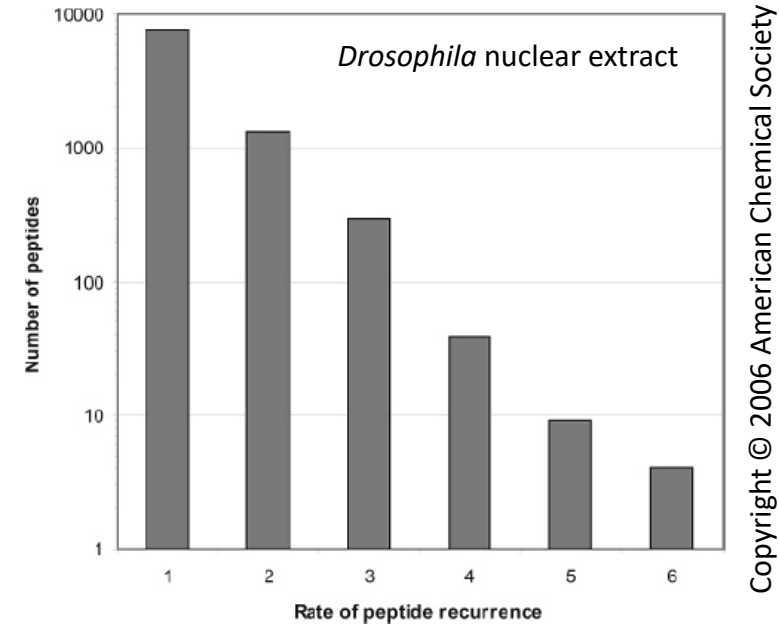

Krijgsveld et al., J. Proteome Res. 2006, 5, 1721-1730

- **Small redundancy between IEF fractions** (13 cm strip, 20 fractions)
- 96% of all peptides were found in two fraction at the maximum (82% in a single fraction)
- 16 h rehydratation + 2-4 h focusing

# Separation visualization

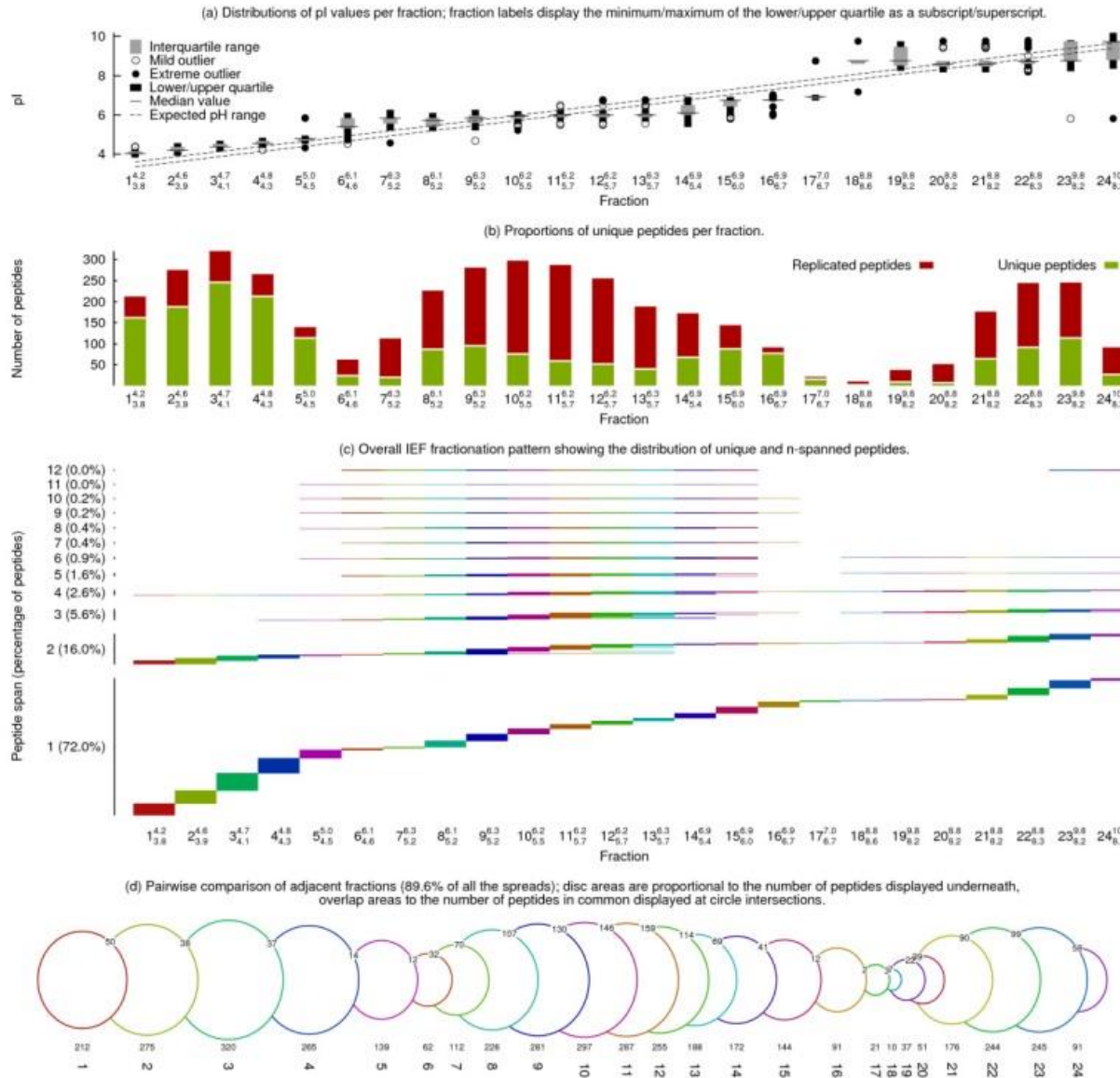

- Peptide **pI distribution** per fraction

- Percentage of **unique peptides** per fraction

- Distribution of unique and **n-spanned peptides**

- **Identification spread** of peptides across adjacent fractions

# Off-gel electrophoresis (OGE)



 Agilent Technologies

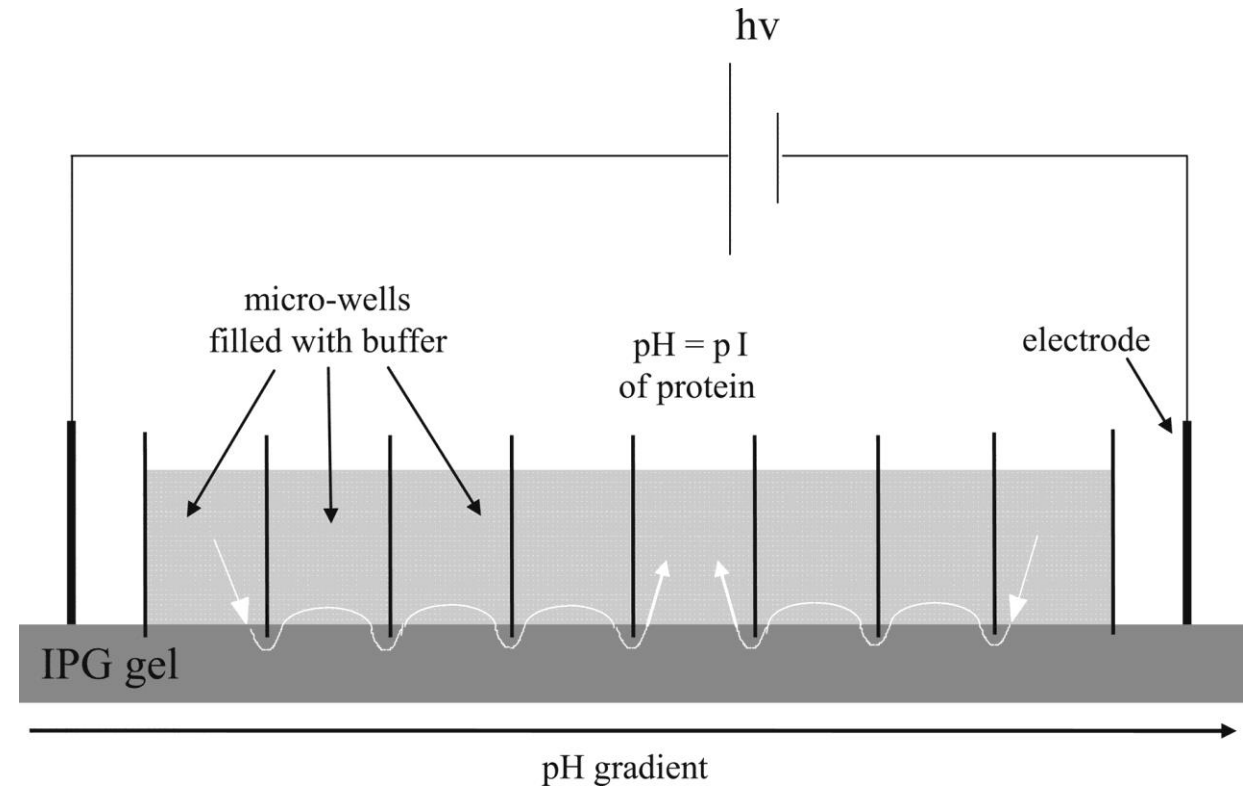

Horth et al., *Mol. Cell. Proteomics* 2006, 5, 1968-1974

Ros et al., *Proteomics* 2002, 2, 151-156  
Michel et al., *Electrophoresis* 2003, 24, 3-11

# Off-gel in practice

## CONFIGURATIONS:

- Peptides or proteins
- 12 or 24 wells (13 or 24 IPG strips)
- High and low resolution



## PROCEDURES:

- Assemble the IPG strips, frames and electrodes
- IPG strip rehydration (15- 30 min)
- Sample loading in the wells
- Mount the electrodes
- Apply the voltage (limit current)



# Focusing efficiency of Off-gel

Numerical studies to characterize off-gel IEF in a 3-compartment device:

- **Electric field vectors**: the electric field arriving from the gel enters the well on the left end side, and occupies the full volume of the well
- **Concentration isovalues** of angiotensin II: focusing time depends on slope at  $pI$ ; however diffusion (“vertical focusing”) reduce the difference

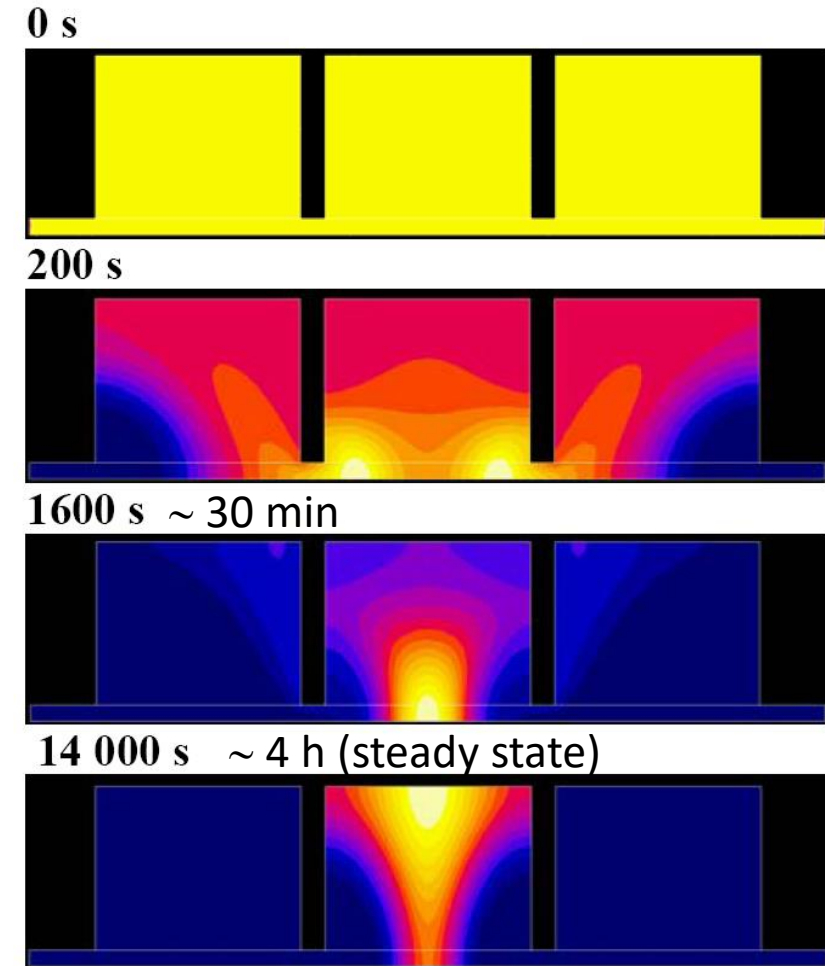
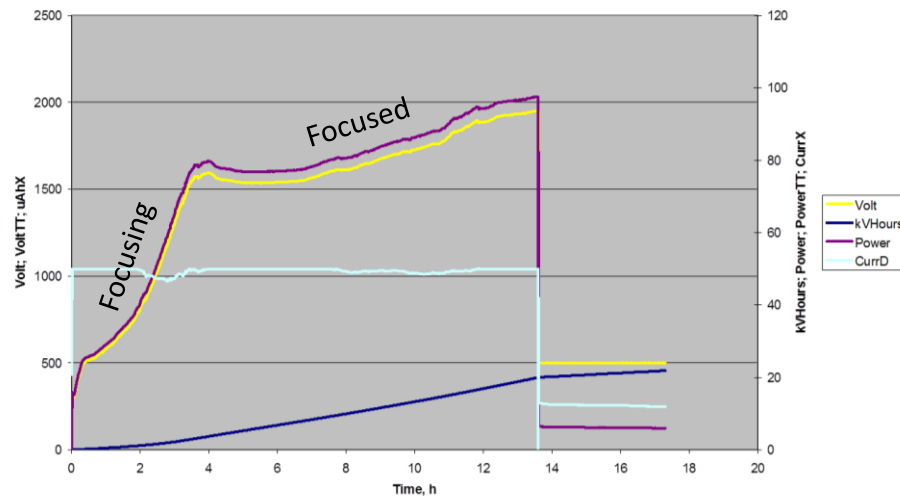

Lam et al., J. Proteome Res. 2007, 6, 1666 - 1676

# Focusing efficiency of Off-gel

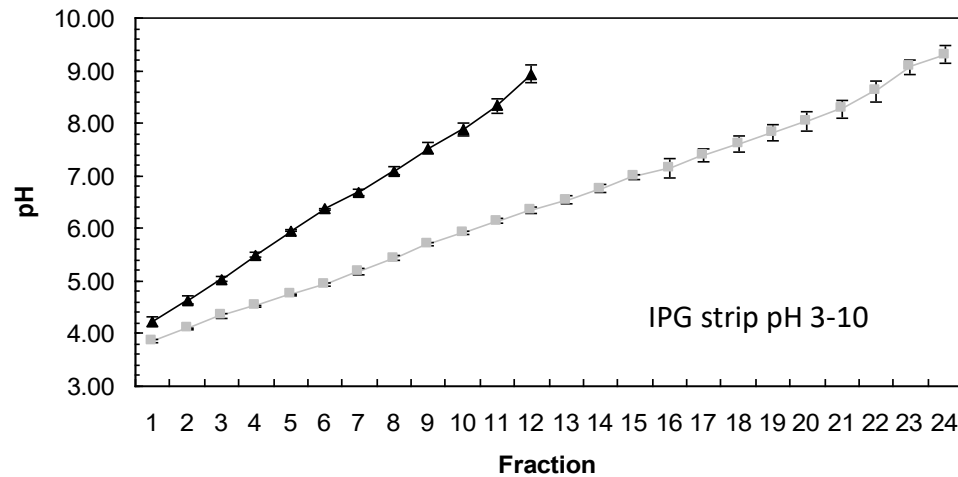

pH measurements without any sample:

- 24 wells: RSD from 0.2 to 2.7% (mean 1.2%) => mean  $\Delta\text{pH} = 0.24$  between wells

- 12 wells: RSD from 0.3 to 2.4% (mean 1.3%) => mean  $\Delta\text{pH} = 0.43$  between wells

Charge derivative  $dz/d\text{pH}$  at  $pI$ : experimental data with off-gel IEF

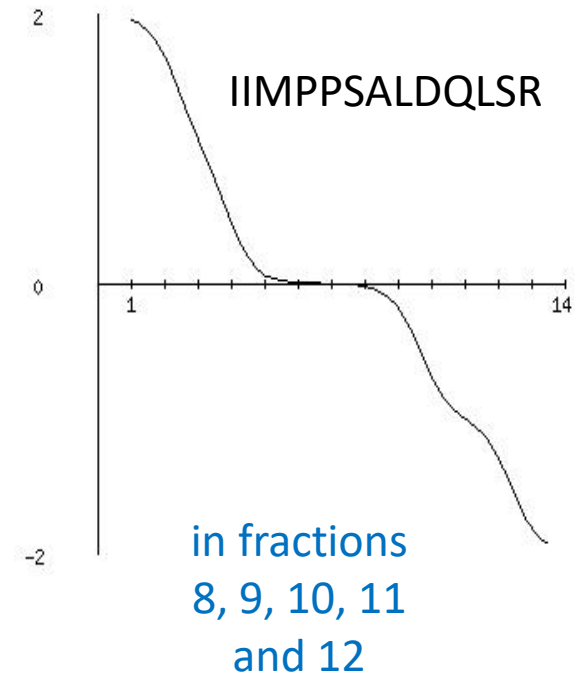
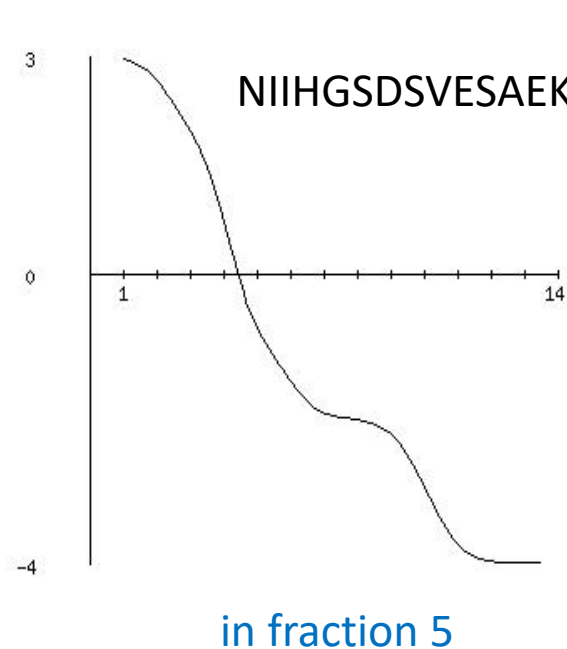

# Focusing efficiency of Off-gel

## Influence of salts

Digests of *post-mortem* cerebrospinal fluid separated by OGE (TOF/TOF MS)

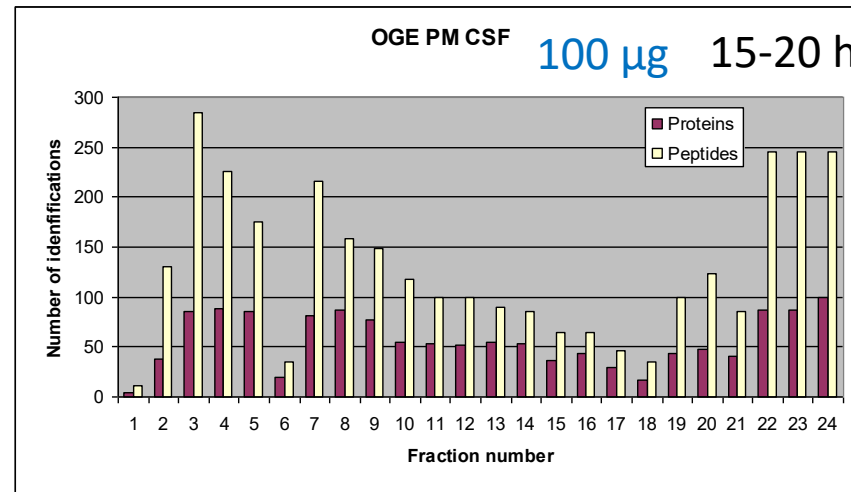

364 proteins (3590 peptides)

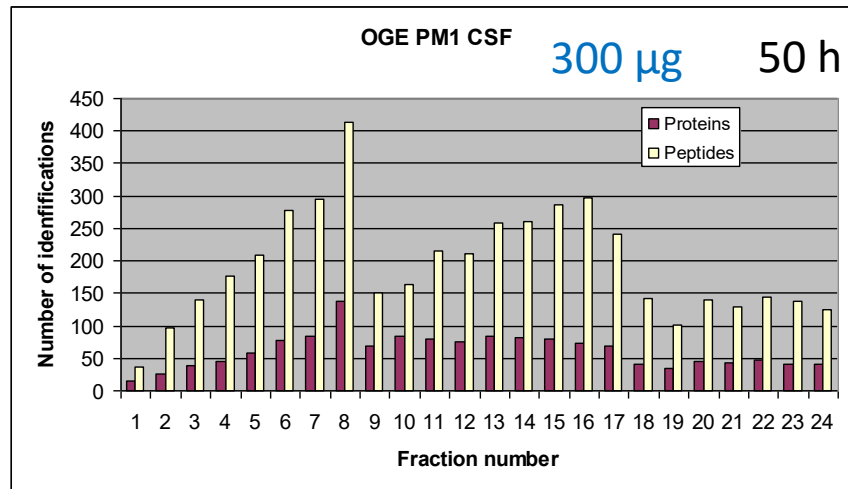

273 proteins (5186 peptides)

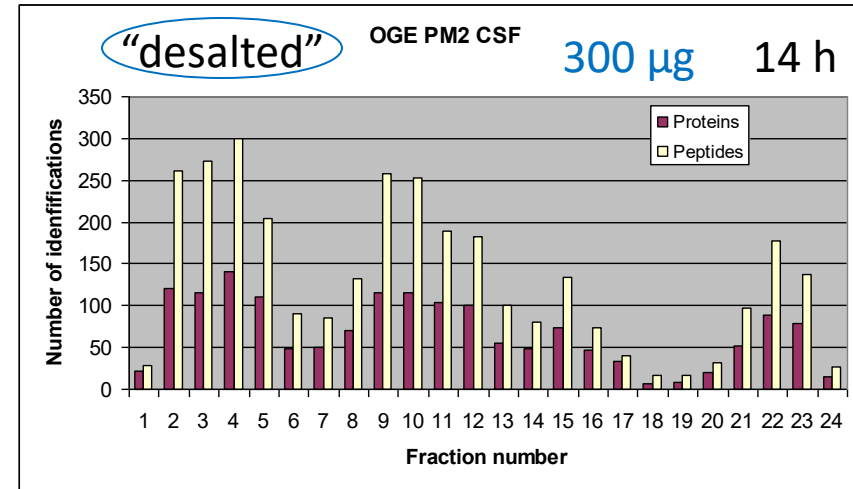

582 proteins (4019 peptides)

# Reproducibility and orthogonality with RP-LC

Cerebrospinal fluid

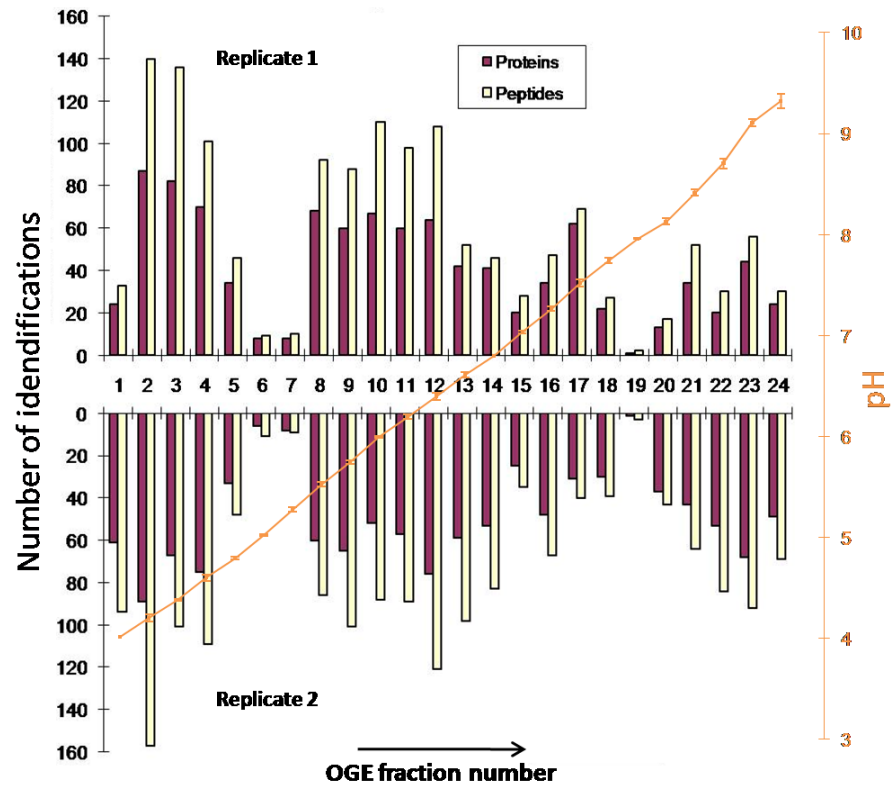

Dayon et al., *Chimia* 2010, 64, 132-135

- Reproducibility

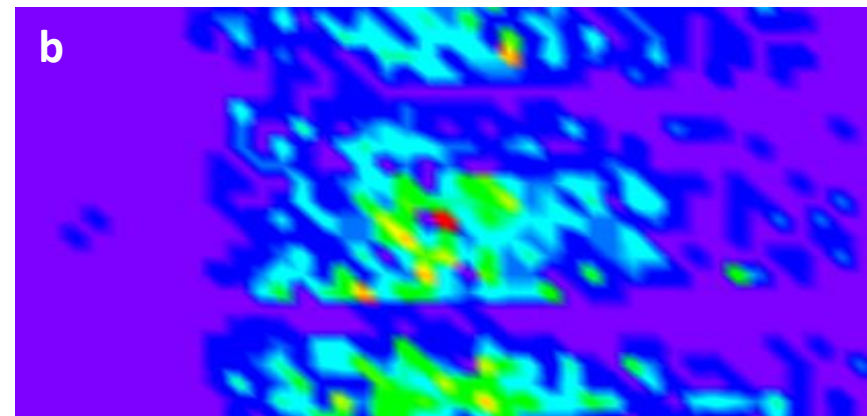
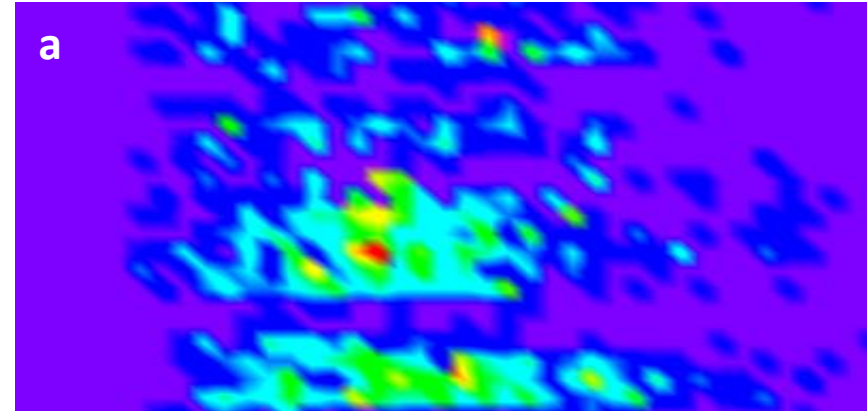

Dayon et al., *Anal. Chem.* 2010, 82, 848-858

- Orthogonality

# Off-gel IEF reproducibility

		Fraction number	1	2	3	4	5	6	7	8	9	10	11	12
		Average pH	4.02	4.21	4.38	4.60	4.80	5.03	5.28	5.53	5.75	6.00	6.20	6.40
		pH RSD / %	0.9	0.2	0.6	0.3	0.1	0.4	0.4	0.4	0.1	0.4	0.6	0.4
TOF/TOF	Unique peptides (sample 1)	31	134	135	97	43	9	10	92	88	110	98	108	
	Unique peptides (sample 2)	86	150	99	108	48	11	9	84	99	87	89	118	
	Common peptides / %	27	59	43	55	57	54	33	49	60	54	51	50	
LTQ-OT	Unique peptides (sample 1)	210	376	373	330	213	65	80	316	336	350	363	359	
	Unique peptides (sample 2)	206	344	256	333	185	55	57	274	307	312	297	334	
	Common peptides / %	40	57	44	52	52	56	54	55	53	52	52	55	

- 80% of the peptides in a unique fraction

- 49% in the same off-gel fraction between sample 1 and sample 2 (DDA mode)

		Fraction number	13	14	15	16	17	18	19	20	21	22	23	24
		Average pH	6.61	6.80	7.04	7.27	7.52	7.75	7.96	8.13	8.42	8.71	9.11	9.33
		pH RSD / %	0.0	0.2	0.3	0.5	0.1	0.4	0.3	0.6	0.6	0.4	0.8	1.6
TOF/TOF	Unique peptides (sample 1)	52	46	26	43	68	25	2	16	48	26	55	27	
	Unique peptides (sample 2)	97	81	35	64	40	35	3	42	59	77	88	65	
	Common peptides / %	26	27	25	35	35	30	67	21	34	27	42	26	
LTQ-OT	Unique peptides (sample 1)	300	342	226	277	337	119	22	164	312	247	307	264	
	Unique peptides (sample 2)	301	288	248	247	274	79	19	139	246	270	238	201	
	Common peptides / %	55	56	48	55	53	46	41	54	38	45	49	50	

- 54% of the peptides were commonly identified in sample 1 and sample 2

# Application of peptide IEF: MS data validation/filtering through p/

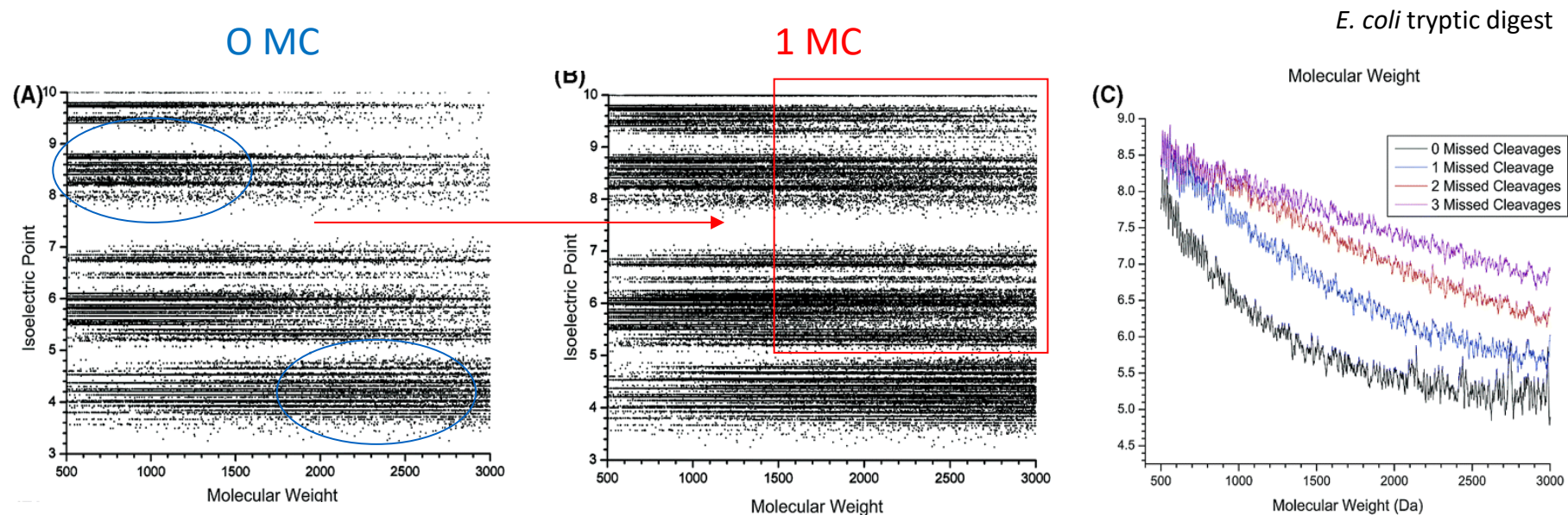

Cargile et al., *J. Proteome Res.* 2004, 3, 112-119

Copyright © 2004 American Chemical Society

⇒ data is spread out over the **entire mass/pI plot**

⇒ MC lead to an increase in the absolute number of peptides, but also an increase in the medium to high molecular weight range of the middle to high pI (6.0-9.5)

⇒ as the peptide increase in mass, the average pI decreases (fig. c)

⇒ as the number of MC increases, the average pI increases (fig. c)

# Application of peptide IEF: MS data validation/filtering through pI

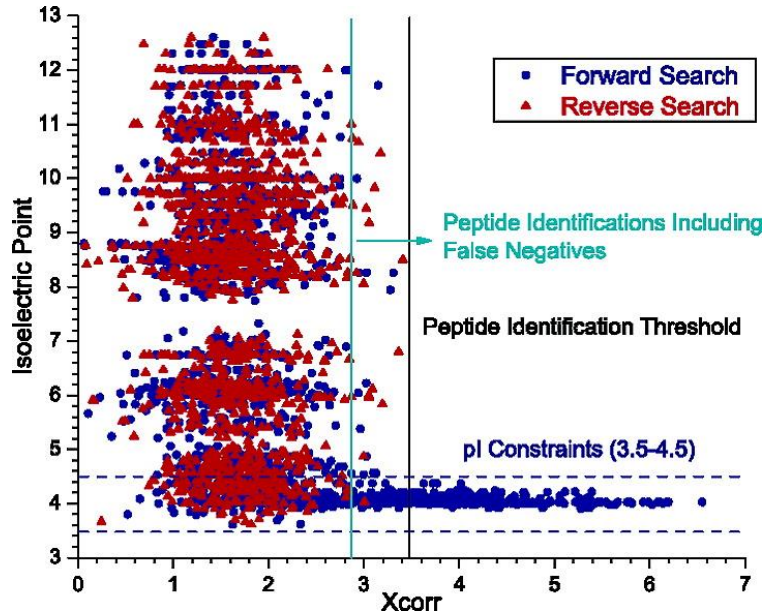

Cargile et al., J. Proteome Res. 2004, 3, 1082-1085

Copyright © 2004 American Chemical Society

Reducing of false positive rate by filtering of peptides based on pI

=> Importance of pI calculation algorithms

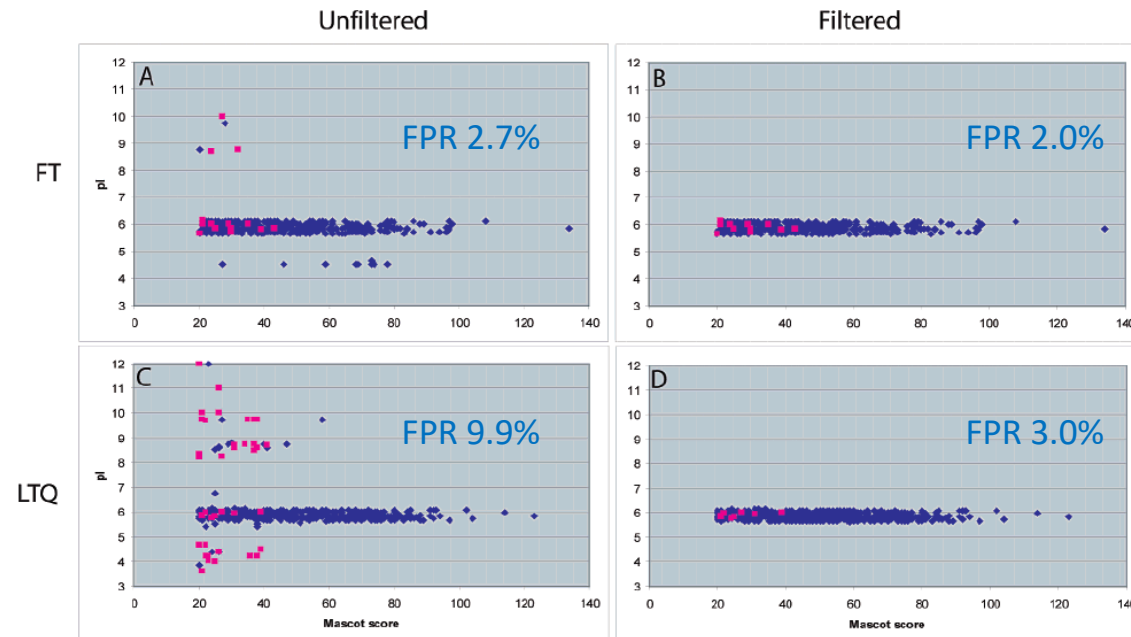

Copyright © 2006 American Chemical Society

Krijgsveld et al., J. Proteome Res. 2006, 5, 1721-1730

# Application of peptide IEF: pI and mass accuracy

## Accurate mass tags (AMT)

- 1) Shotgun LC MS/MS
- 2) Find unique peptides (no isobars) at 1 ppm accuracy) representing a protein

=> Screening of comparable samples by LC FT-ICR-MS looking at AMT

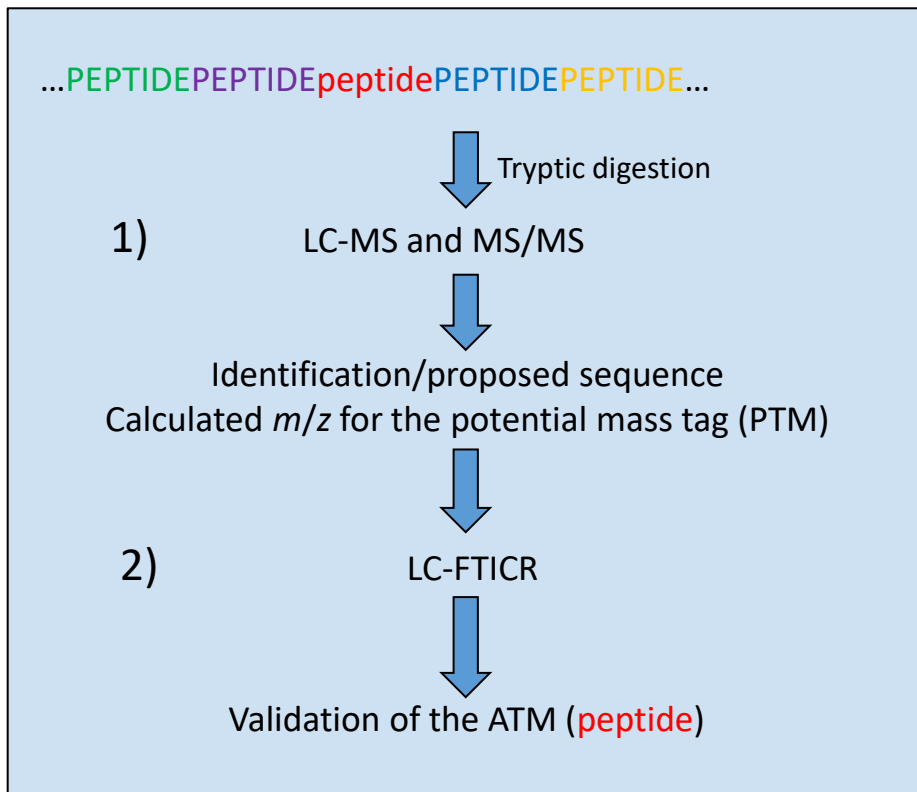

Smith et al., Proteomics 2002, 2, 513–523

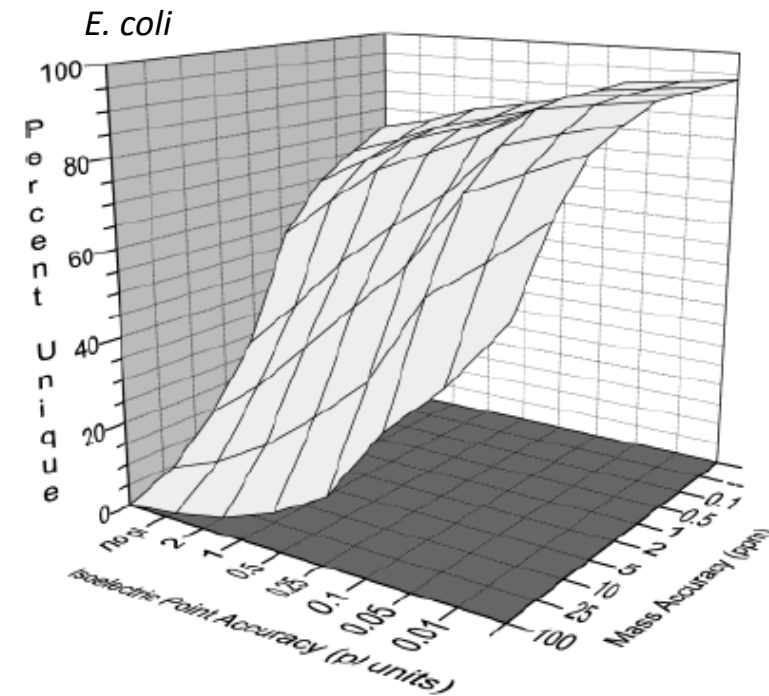

Copyright © 2004 American Chemical Society

Cargile et al., Anal. Chem. 2004, 76, 267-275

Find complement to mass measurement  
to discriminate information:

- retention time in LC
- pI

...

# Application of peptide IEF: IEF and chemical tagging for phosphoproteomics

*Anal. Chem.* **2007**, *79*, 2007–2014

## **Selective Enrichment and Fractionation of Phosphopeptides from Peptide Mixtures by Isoelectric Focusing after Methyl Esterification**

**Chong-Feng Xu,<sup>†</sup> Huaibin Wang,<sup>‡</sup> Daming Li,<sup>§</sup> Xiang-Peng Kong,<sup>‡</sup> and Thomas A. Neubert<sup>\*†</sup>**

2044

*Electrophoresis* **2007**, *28*, 2044–2052

**Chien-Wen Hung<sup>1</sup>  
Dieter Kübler<sup>2</sup>  
Wolf D. Lehmann<sup>1</sup>**

Research Article

### **pI-based phosphopeptide enrichment combined with nanoESI-MS**

<sup>1</sup>Central Spectroscopy,  
German Cancer Research Center,  
Heidelberg, Germany  
<sup>2</sup>Biomolecular Interactions Group,  
German Cancer Research Center,  
Heidelberg, Germany

*Journal of Proteome Research* **2007**, *6*, 1153–1157

research articles **Journal of proteome**  
●research

### **Isolation of Phosphopeptides by pI-Difference-Based Electrophoresis**

Yingda Xu, Robert Sprung, Sung Won Kwon, Sung Chan Kim, and Yingming Zhao\*

# Application of peptide IEF: IEF and chemical tagging for phosphoproteomics

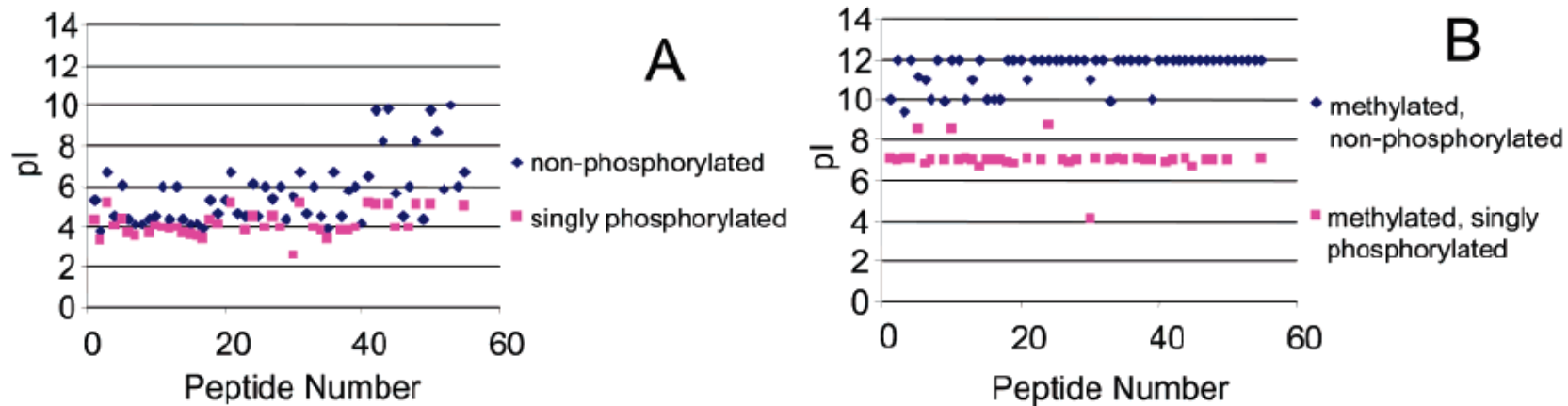

Xu et al., J. Proteome Res. 2007, 6, 1153-1157

Copyright © 2007 American Chemical Society

pI values of all peptides increase after esterification of acidic groups, However, methylated phosphopeptides have much lower pIs than methylated non-phosphopeptides.

**Table 1. Prediction of the pIs for Phosphopeptides Using pIMethylation and Scansite**

protein	seq. no.	sequence	MW+H		pI (w/o methylation)		pI (methylation)	
			w/o methylation	methylation	Scansite	pIMethylation	pIMethylation	observed pI <sup>a</sup> (pH 6.3–8.3 gel)
β-casein	33–48	FQpSEEQQTEDELQDK	2061.83	2159.94	3.37	3.34	7.00	6.7–7.1
	1–25	RELEELNVPGEIVepSLpSpSpSEESITR	3122.27	3234.40	2.51	1.66	1.68	6.7–7.9
α-S1-casein	106–119	VPQLEIVPNpSAEER	1660.80	1716.86	3.69	3.67	6.97	6.7–7.1
	104–119	YLGEYLIVPNpSAEER <sup>c</sup>	1832.83	1888.89	3.69	3.67	7.00	6.3–6.7
	43–58	DIGpSEpSTEDQAMEDIK	1927.69	2025.80	2.78	2.33	3.84	≤6.3–6.7 <sup>b</sup>
	104–119	YKVPQLEIVPNpSAEER	1951.95	2008.01	4.26	4.25	8.61	7.9–8.3
	59–79	QMEAEpSlpSpSpSEEIVPNpSVEQK	2720.91	2805.00	1.93	1.02	1.02	n/a
α-S2-casein	138–149	TVDMEpSTEVFTK	1466.61	1522.67	3.60	3.58	6.66	6.7–7.1
	138–150	TVDMEpSTEVFTKK	1594.70	1650.76	4.14	4.13	8.14	7.5–7.9 <sup>b</sup>
	1–24	KNTMEHVpSpSpSEESIIpSQETYKQEK	3132.20	3216.29	3.59	3.52	5.75	≤6.3–6.7 <sup>b</sup>

<sup>a</sup> Observed pI was the pH fraction that contained the majority of phosphopeptides in the 2-h focusing experiment. <sup>b</sup> Phosphopeptides that were observed only in the 1-h focusing experiment. <sup>c</sup> Alternative splice form of this peptide.

Copyright © 2007 American Chemical Society

# Application of peptide IEF: pI of acetylated peptides

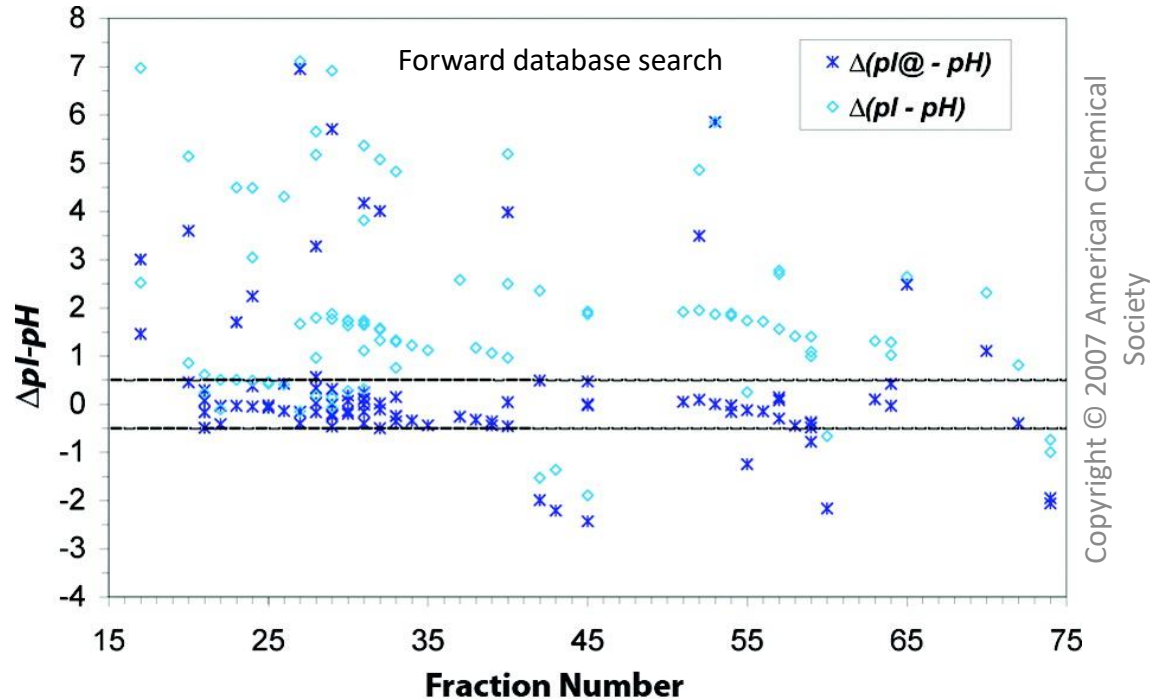

Xie et al., J. Proteome Res. 2007, 6, 2019-2026

Improving the identification of PTMs which cause a shift to pI of peptides

pI of acetylated peptides

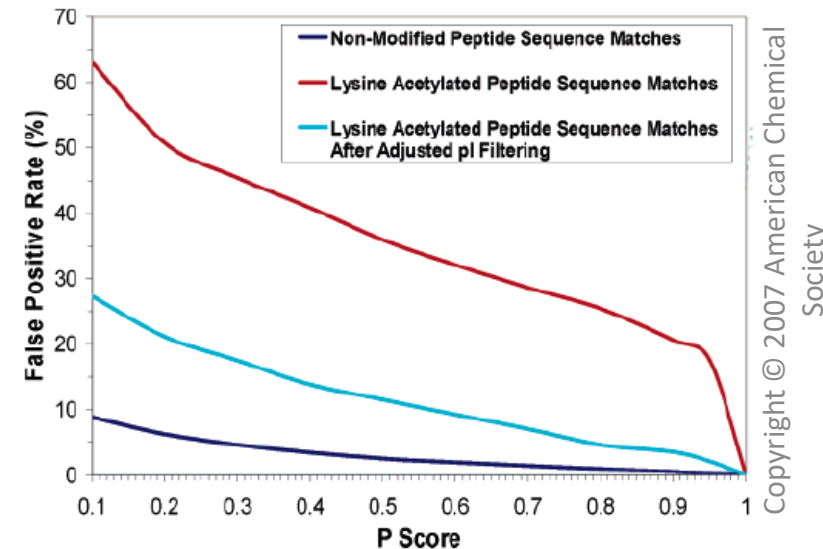

Xie et al., J. Proteome Res. 2007, 6, 2019-2026

# 3. Liquid chromatography (LC) in protein profiling

- Chromatography: generalities
  - Definitions
  - Principles of chromatography
  - Theory and chromatographic performance
- Liquid chromatography (LC)
  - Adsorption
  - Partition
  - Size Exclusion
  - Ion exchange
  - Affinity
- High performance liquid chromatography (HPLC)
- Applications of liquid chromatography in biological research
  - Affinity chromatography
  - Multi dimensional separation

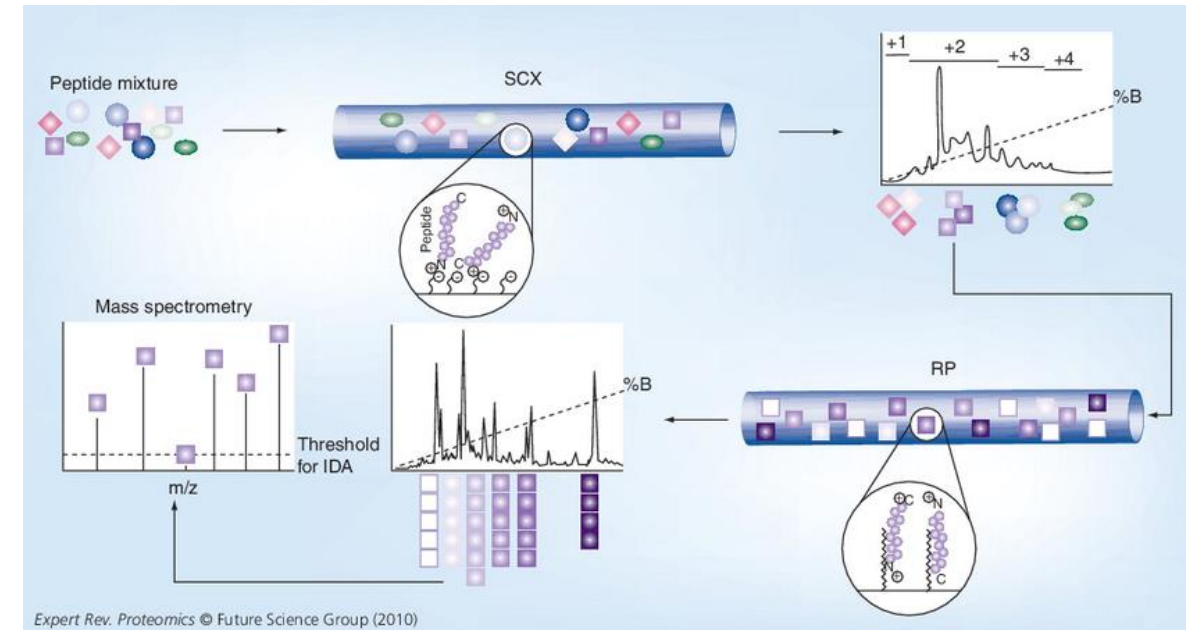
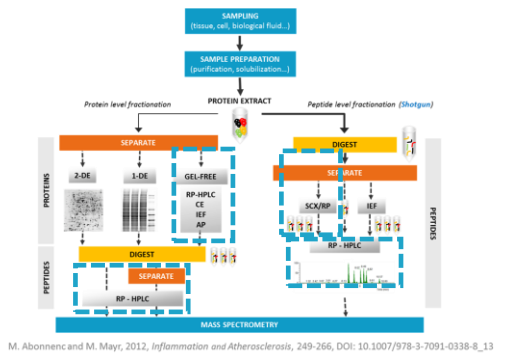

DOI: 10.1586/epr.10.46

# Definition of chromatography

- Chromatography is a [separation](#) technique which involves the interaction of one or more solutes with two phases: a [stationary phase](#) and a [mobile phase](#).
- Sample components are carried by the mobile through the bed stationary phase based on various interactions such as:
  - Adsorption
  - Partition
  - Size Exclusion
  - Ion exchange
  - Affinity

# History of chromatography

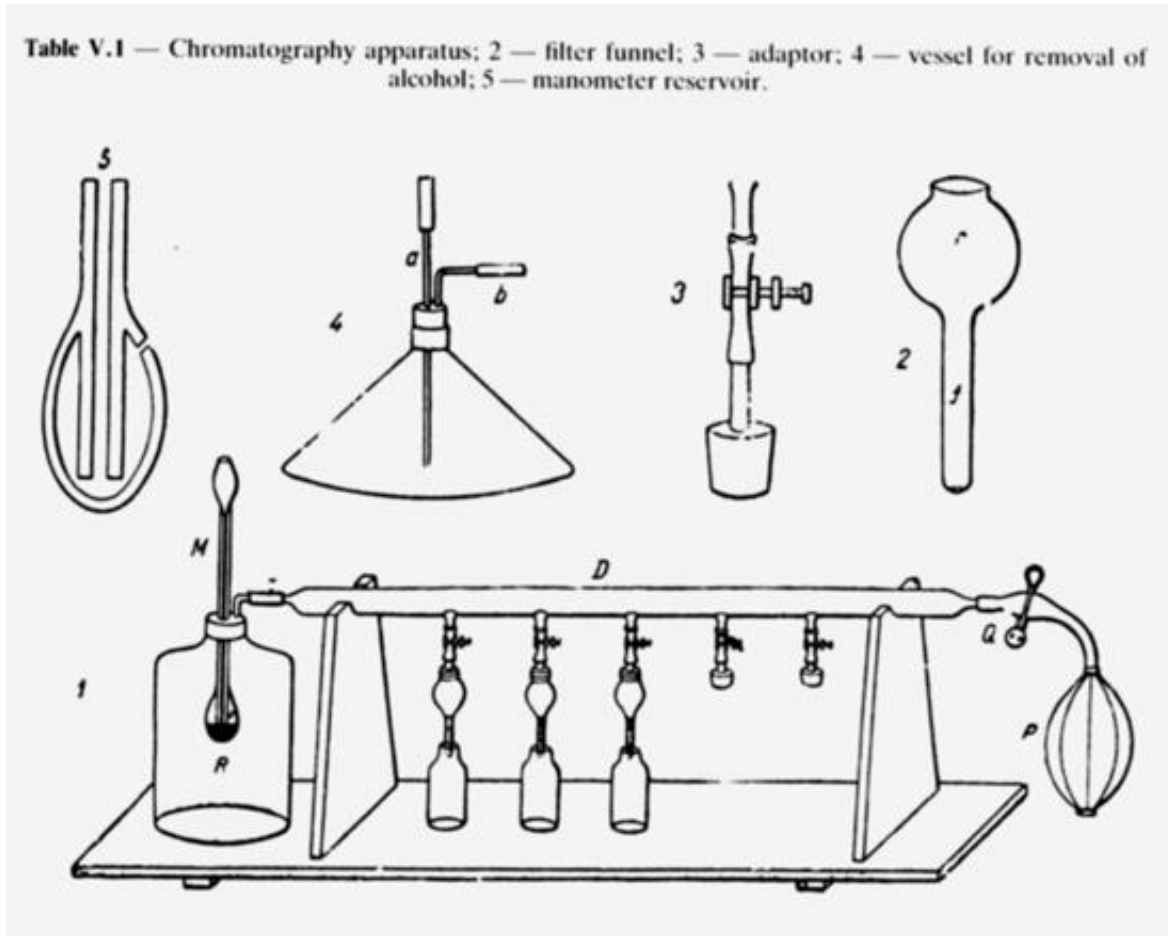

Tswett-Apparatus (1905)



Michail Semjonowitsch Tswett

He used liquid-adsorption column chromatography with calcium carbonate as adsorbent and petrol ether / ethanol mixtures as eluent to separate chlorophylls and carotenoids

# History of chromatography

In 1952, **Archer John Porter Martin** and **Richard Laurence Millington Synge** were awarded the Chemistry Nobel Prize for their invention of partition chromatography

In 1968, High Performance Liquid Chromatography (HPLC) is implemented

In 1979, chiral compounds are separated by HPLC

## 151. A NEW FORM OF CHROMATOGRAM EMPLOYING TWO LIQUID PHASES

### 1. A THEORY OF CHROMATOGRAPHY

### 2. APPLICATION TO THE MICRO-DETERMINATION OF THE HIGHER MONOAMINO-ACIDS IN PROTEINS

By A. J. P. MARTIN AND R. L. M. SYNGE

*From the Wool Industries Research Association, Torridon, Headingley, Leeds*

*(Received 19 November 1941)*

#### INTRODUCTION

IN most forms of counter-current extraction column the very small drop required for the rapid attainment of equilibrium, and hence for high efficiencies, cannot be used owing to the difficulty of preventing it moving in the wrong direction. In the case of a solid, however, for any reasonable size of particle a filter will prevent movement in any undesired direction. Consideration of such facts led us to try absorbing water in silica gel etc., and then using the water-saturated solid as one phase of a chromatogram, the other being some fluid immiscible with water, the silica acting merely as mechanical support. Separations in a chromatogram of this type thus depend upon differences in the partition between two liquid phases of the substances to be separated, and not, as in all previously described chromatograms, on differences in adsorption between liquid and solid phases.

The difficulties of using chromatograms are very greatly lessened when the substances to be separated are coloured, or if colourless can be made visible. Various methods have been used for this [cf. Zechmeister & Cholnoký, 1936; Cook, 1941], though none of these was suitable for our problems. As the substances which we desired to separate were acids, and water was one of our phases, we were able to obtain visual evidence of the presence of any of these acids by adding a suitable indicator to the water with which the gel was saturated.

In the present paper we present an approximate theory of chromatographic separations, and describe an application of the new chromatogram to the micro-determination of the higher monoamino-acids in protein hydrolysates. This method is based on the partition of acetamino-acids between chloroform and water phases, and supersedes the macro-method described by us [Martin & Synge, 1941, 1], being rapid and economical both of materials and of apparatus.

Work is in progress, using ethyl acetate as the less polar phase in the chromatogram, on the separation of the acetyl derivatives of most of the other naturally occurring amino-acids, and the method promises also to be of use in analogous separations of simple peptides.

We wish to stress, however, that the possible field of usefulness of the new chromatogram is by no means confined to protein chemistry. By employing suitable phase pairs, many other substances should be separable. Where water is suitable as one of the phases, an indicator may be used to render visible the separation of organic acids or bases. Even where this is not possible, as with

# Basis of chromatography

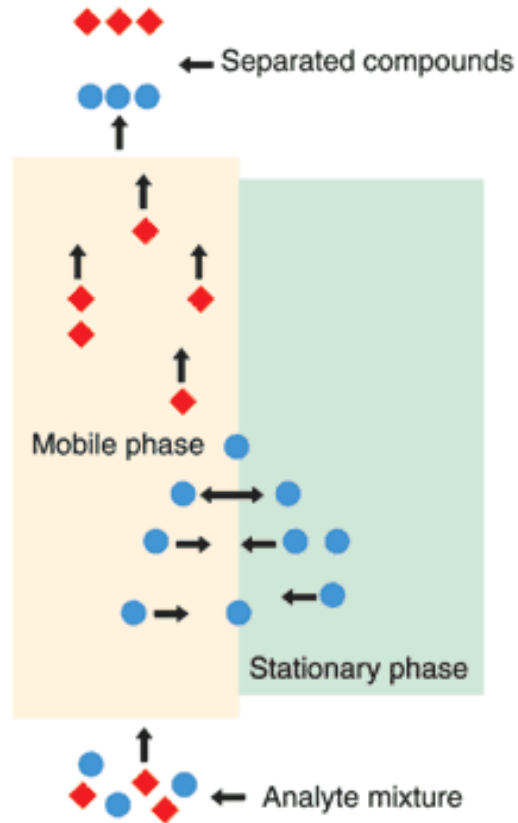

Important to understand the equilibrium that is behind chromatography

$$A_{\text{mobile}} \rightleftharpoons A_{\text{stationary}}$$

Coefficient of distribution (equilibrium constant)

$$K = \frac{C_s}{C_M}$$

stationary  
mobile

- The circle compound • is highly soluble in the stationary phase and partitions into it easily, which retards its flow through the system
- The ♦ compound is less soluble, or repelled by the stationary phase, and this remains more mobile, quickly passing through the system
- This allows efficient separation of the two compounds and is the basis for all chromatography

# Basis of chromatography

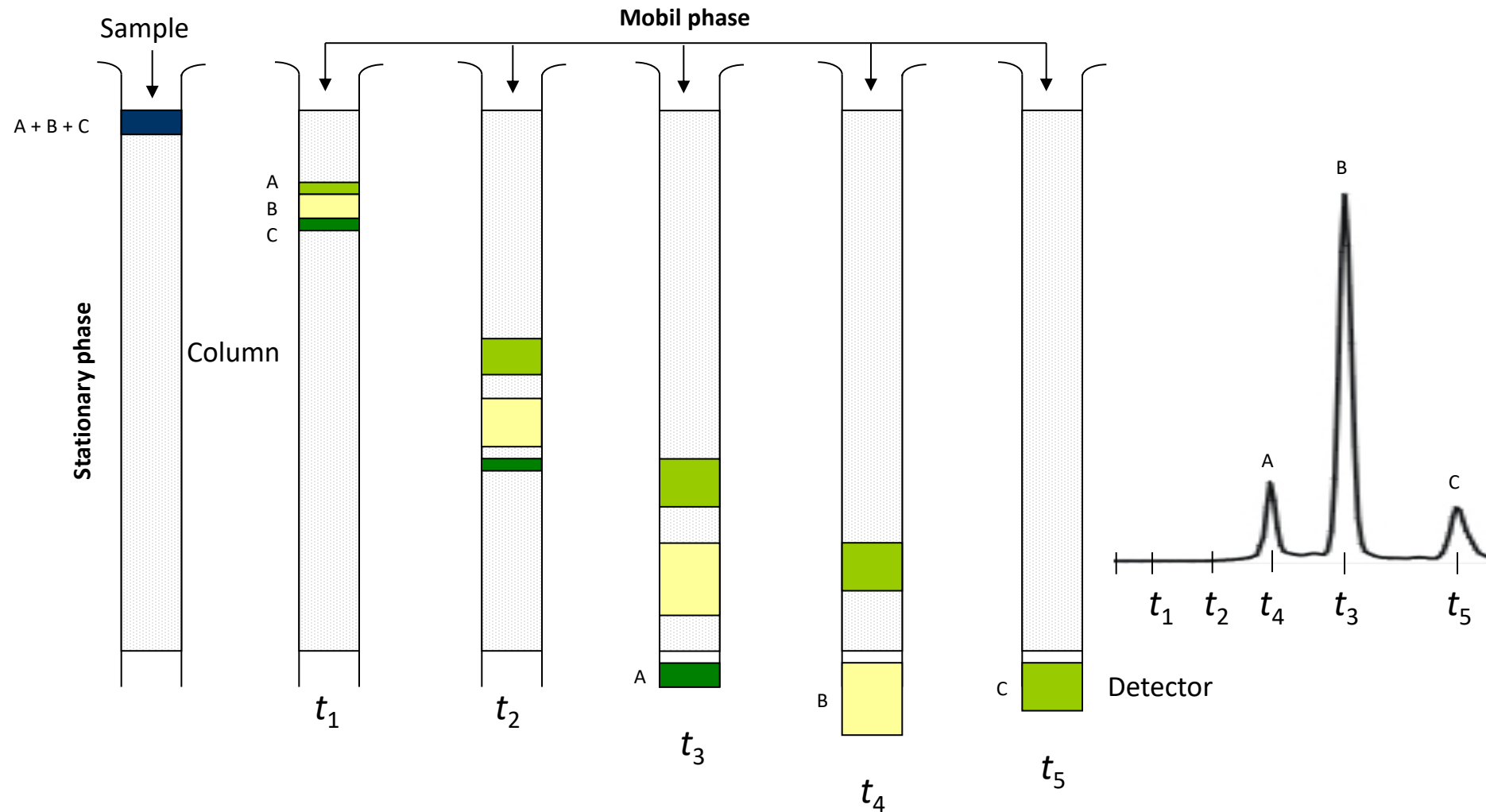

# Basis of chromatography

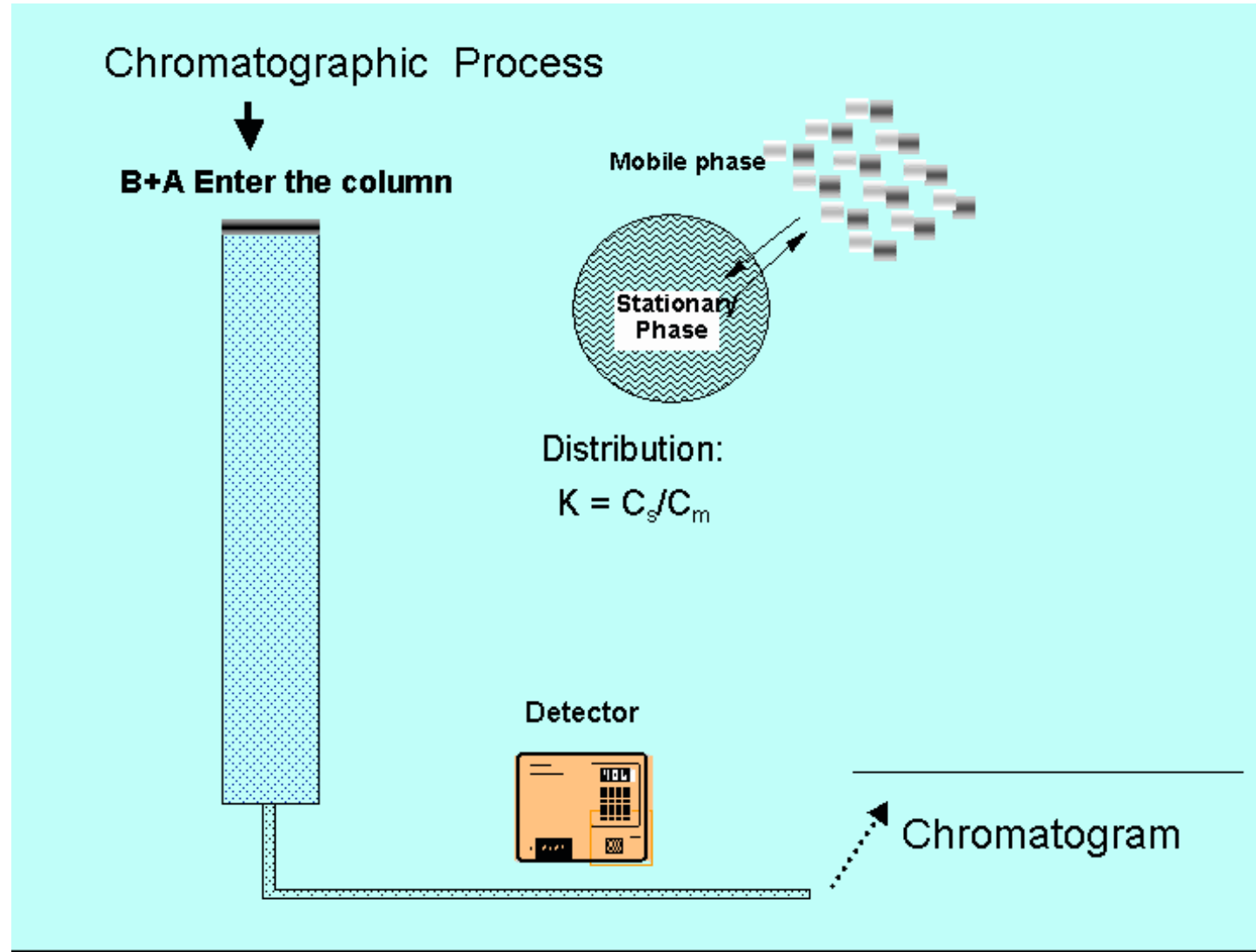

# Different types of chromatography

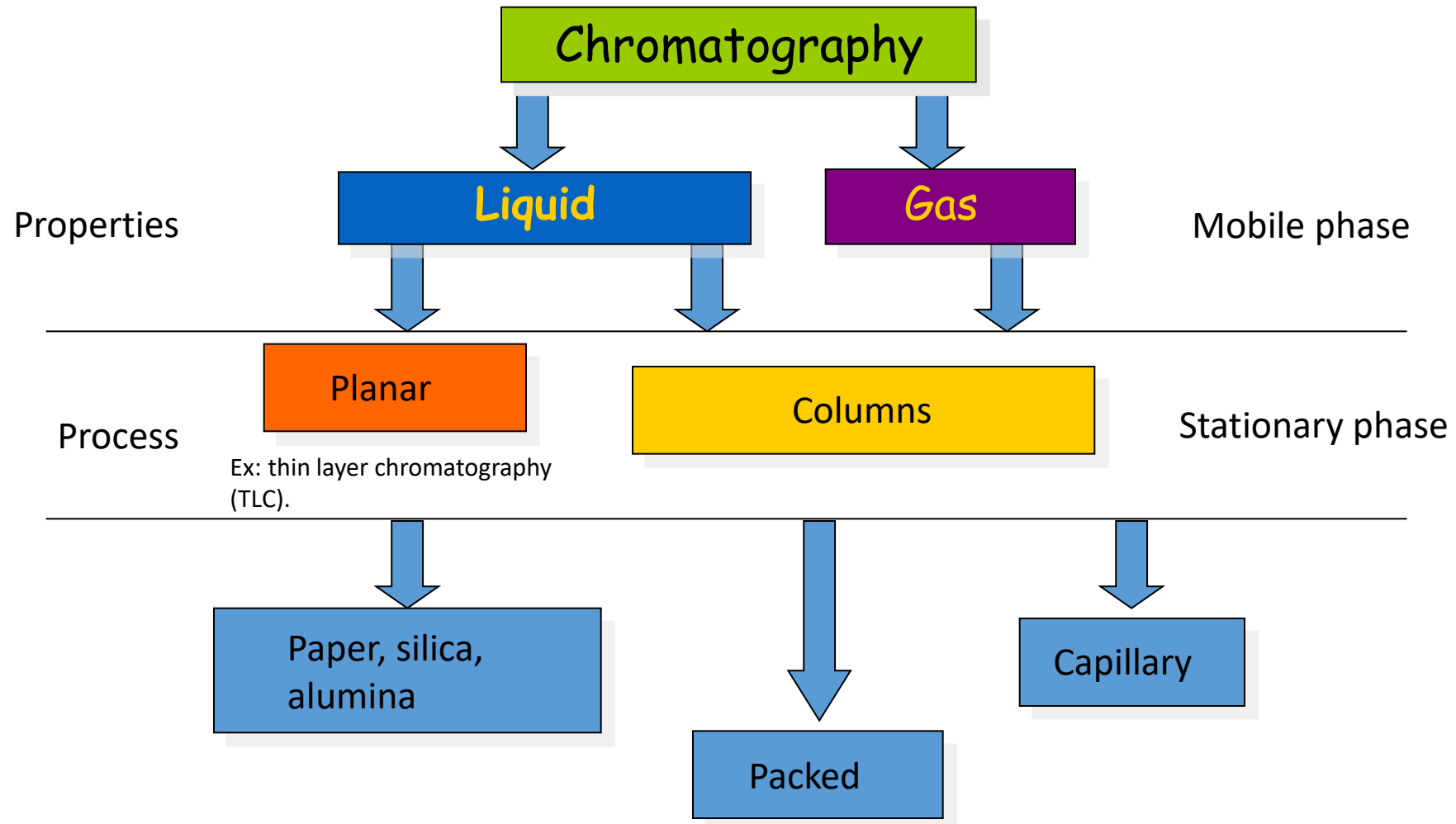

# Chromatography performances and parameters

There are various parameters used to determine how well our chromatography is behaving.

- Selectivity
  - Efficiency
  - Resolution
- [Retention time](#)  
Time taken to reach the detector after injection
  - [Selectivity](#)  
Measurement of the difference in retention between components on the same column
  - [Efficiency](#)  
Measurement of band-broadening, function of peak width and retention
  - [Resolution](#)  
Extent of separation between 2 peaks (how well they are resolved)  
Includes both selectivity and efficiency
  - [Capacity](#)  
Amount of sample that a chromatography system can separate

# Retention time ( $t_R$ )

- Time taken to reach detector after injection ( $t_R$ )
- Measured at peak apex
- Factors that affect  $t_R$  include:
  - velocity (flow rate) of mobile phase
  - chromatographic retention
- Time spent in the stationary phase  $t_R' = t_R - t_0$

• Linear velocity of the analyte:  
$$v = \frac{L}{t_R} \quad (L = \text{length of the column})$$

• Linear velocity of the mobile phase  
$$u = \frac{L}{t_0}$$

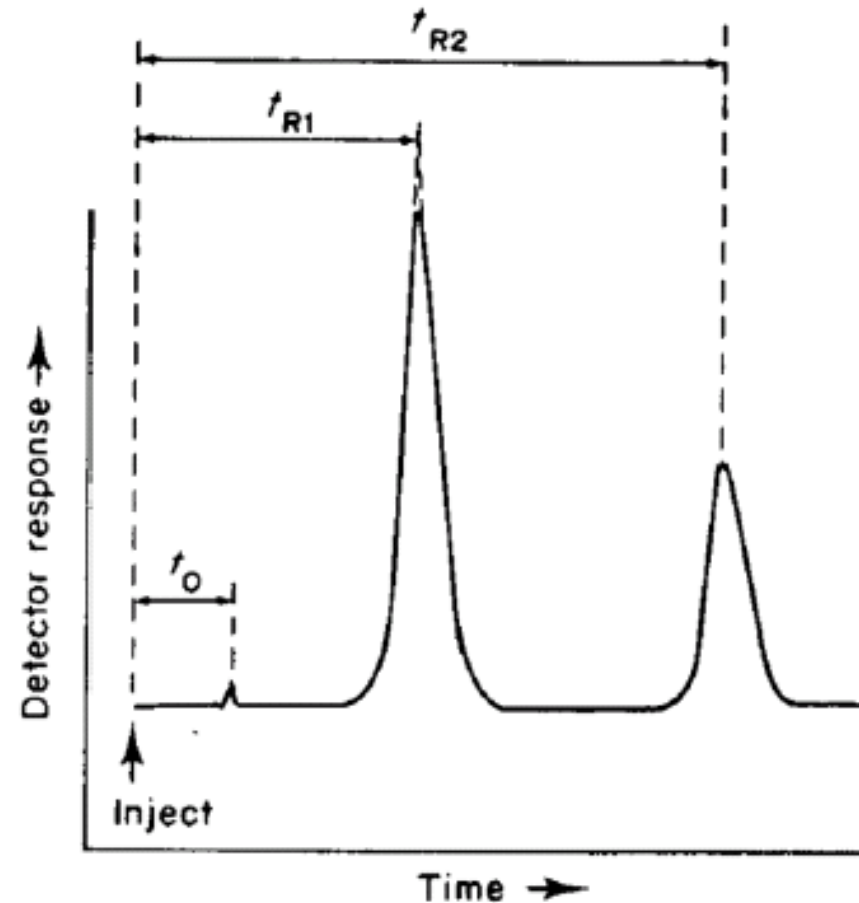

# Selectivity ( $\alpha$ )

- Measurement of the difference in retention between two components in the sample:

$$\alpha = \frac{t_{R2} - t_0}{t_{R1} - t_0} = \frac{k'_2}{k'_1} = \frac{t'_{R2}}{t'_{R1}}$$

- $t_{R1}$  and  $t_{R2}$  are retention times for compounds 1, 2
- $k'_1, k'_2$  = capacity factors for compounds 1, 2
- Separation factor doesn't account for peak widths

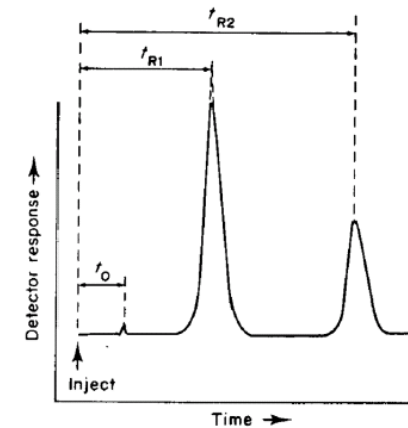

⊗  $A_{\text{mobile}} \rightleftharpoons A_{\text{stationary}}$   
 $B_{\text{mobile}} \rightleftharpoons B_{\text{stationary}}$  (the more retained)

$\alpha = \frac{k_B}{k_A}$  (always > 1)

⊗ Capacity factor  $k'_A = \frac{C_S V_S}{C_M V_M} = K_A \frac{V_S}{V_M}$   
 $k'_B = K_B \frac{V_S}{V_M}$

↗ quantity in stationary phase  
 ↘ quantity in mobile phase

# Efficiency and band broadening

After injection, a narrow band is broadened during its movement through the column by:

- multiple path of analyte
- Longitudinal diffusion
- mass transfer between phases

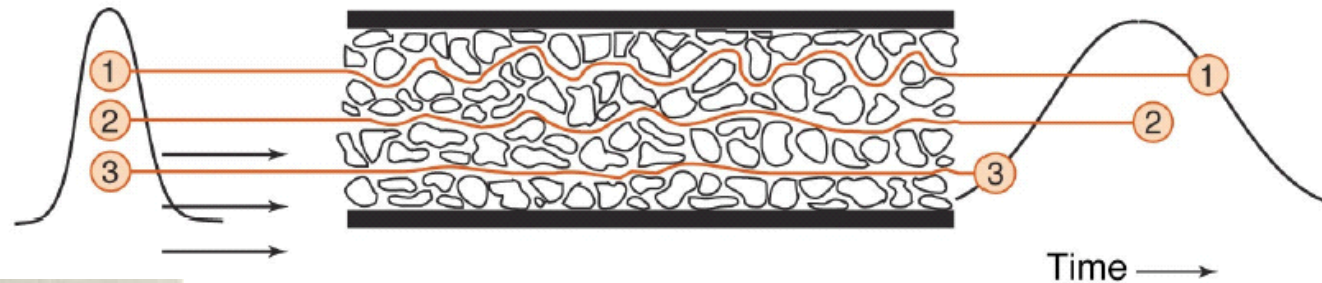
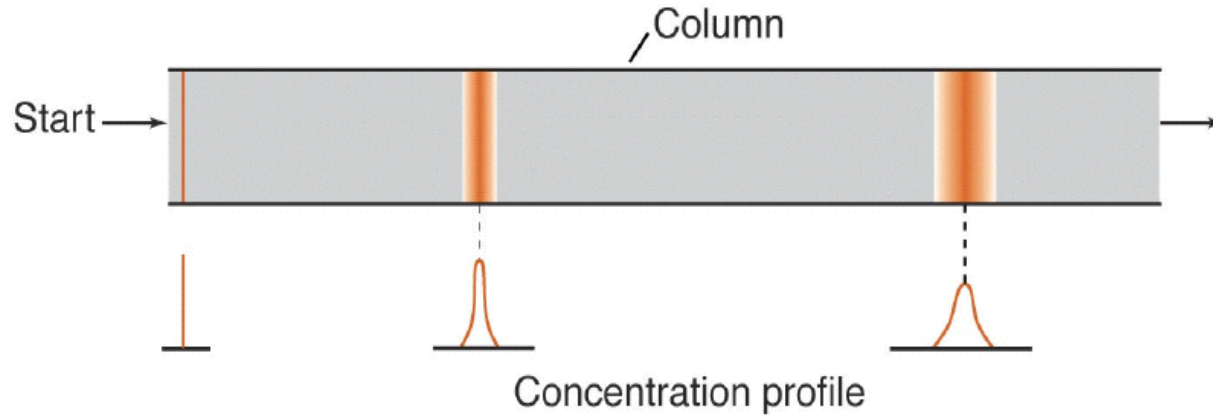

e.g.; Multiple path + Molecular diffusion.  
 + mass transfer between phases.  
 (resistance to mass transfer.)

↑  
 ↓  
 interact Paks so pushed by the mobile phase (stay more on the mobile P)

velocity →

The higher the velocity of mobile phase, the worse the broadening becomes.  
 (against the equilibrium.)

The higher the column band broadening, the smaller the number of components that can be separated.

The sharpness of the peak is an indication of how good, or efficient a column is.

# Efficiency and band broadening

- The peak width is an indication of peak sharpness and, thus, an indication of the column efficiency
- The narrower the peaks, the better the ability to separate components
- Efficiency is a measurement of the band-broadening of a column. It is a function of peak width and retention volume (or retention time)

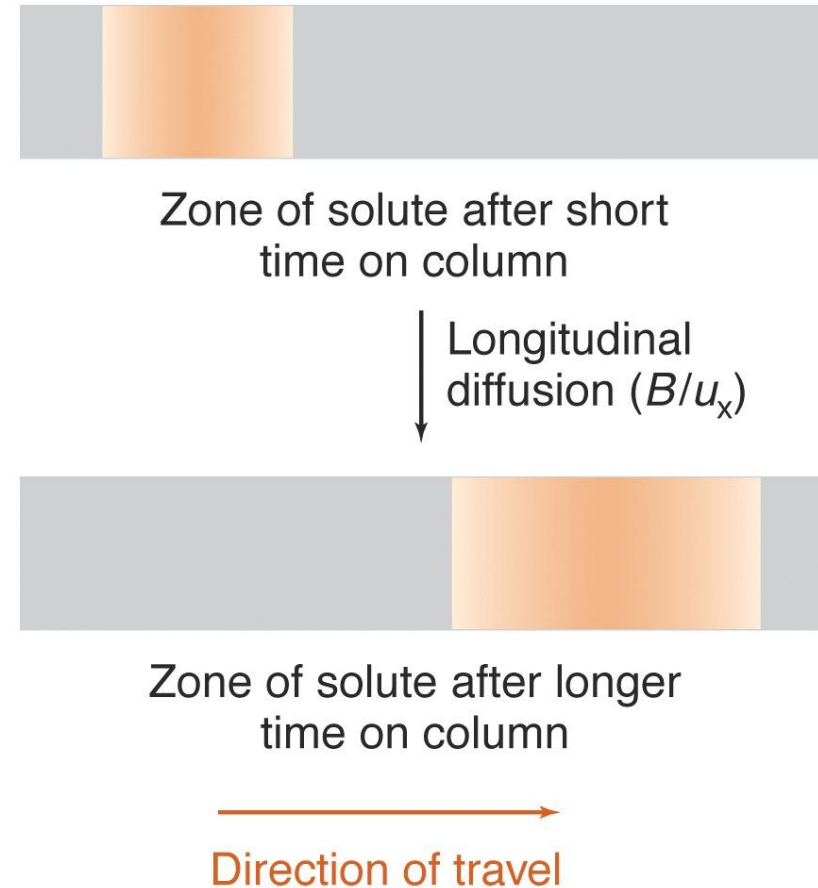

# Efficiency and number of theoretical plates ( $N$ )

- It is primarily controlled by: column length, flow rate, particle size
- Flow rate is the only parameter which can be changed from run to run on the same column.
- The plate number  $N$  depends on column length  $L$  : the longer the column, the larger the plate number. Therefore, the plate height term  $h$  has been introduced to measure the efficiency of a column.  $h = L/N$
- The lower the plate height and the higher the plate number, the more efficient the chromatographic column

Number of plates in a column  $N$  (the more plates the better)

The plate height (height equivalent to a theoretical plate)  
**HETP** (the smaller the better)

$HETP = \frac{L}{N}$

small

big (in cm)

# Theoretical plate model

- The chromatographic column is divided into a number of separate layers, called theoretical plates
- Separate partitioning of the sample between the stationary and mobile phase occur in these "plates"
- The analyte moves down the column by transfer of equilibrated mobile phase from one plate to the next
- This model serves as a way of measuring column efficiency by stating:
  - The number of theoretical plates in a column,  $N$  (the more plates the better)
  - The plate height (the smaller the better)
  - where  $w$  is the peak width at baseline
  - Columns behave as if they have different numbers of plates for different solutes in a mixture

$$HETP = \frac{L}{N}$$

$$N = \left( \frac{4 t_R}{w} \right)^2$$

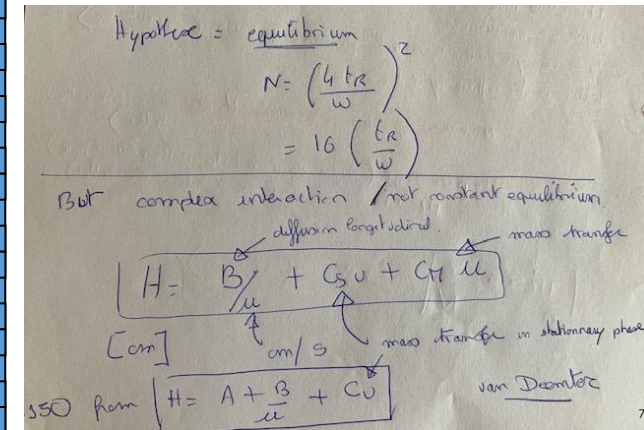
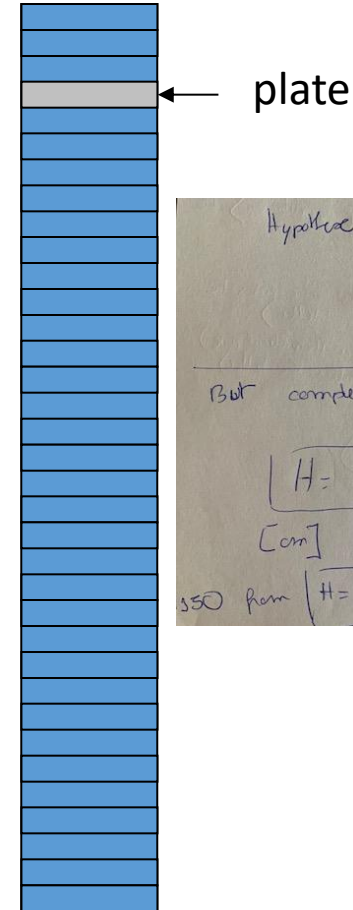

# Resolution

- Although the selectivity factor  $\alpha$  describes the separation of band centres, it does not take into account peak widths
- The resolution measures how well species have been separated
- The resolution  $R$  of two species, A and B, is defined as

$$R = \frac{[t_{R2} - t_{R1}]}{\frac{1}{2}(w_1 + w_2)}$$

where  $t_R$  is the retention time and  $w$  is the peak width at baseline.

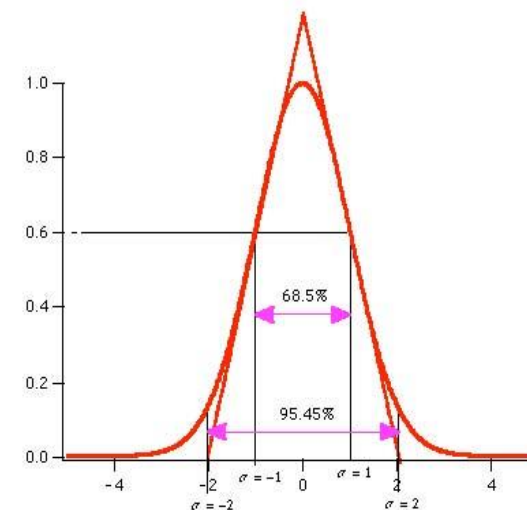

# Resolution

- Resolution is the difference in retention (time or volume) divided by the average base peak width
- $R$  is a measure of two separate parameters – selectivity and efficiency

FIGURE 13.5 ►  
Improving resolution.

(a) The two partially resolved components can be resolved more completely by (b) sharpening the zones, (c) spreading them further apart, or both. Assume the flow rate is the same for all three chromatograms and the samples are identical. The conditions of (c) are not as good as those in (b); it takes longer to obtain a separation of the same quality.

Note that the sensitivity of the vertical scale in the middle chromatogram is decreased. If the vertical scales were all the same, the peak heights of (b) would be significantly larger than those of (a) or (c). However, the peak areas in all three would be equal since the quantities of analytes are equal.

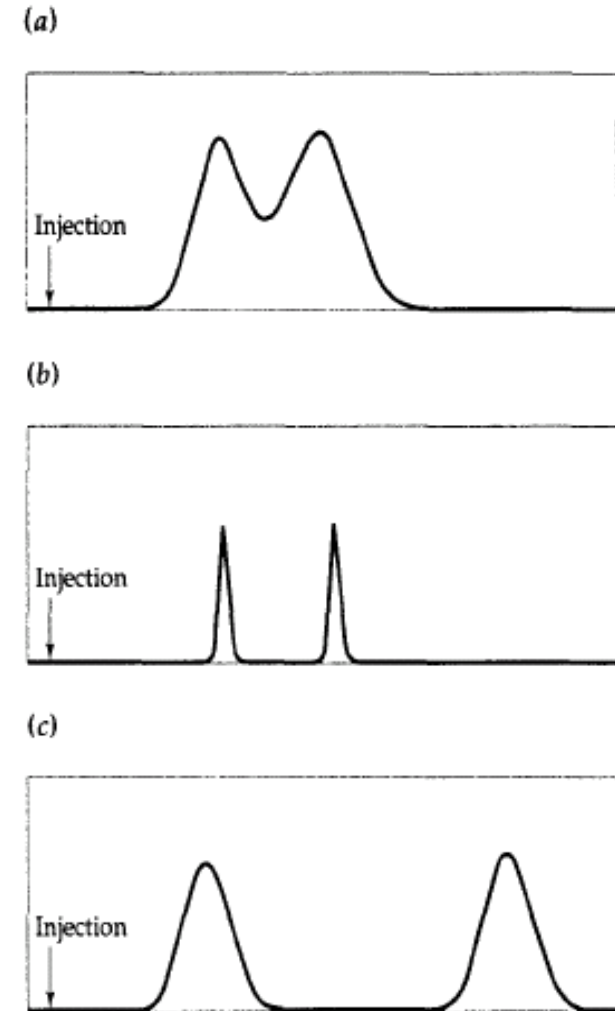

# Resolution

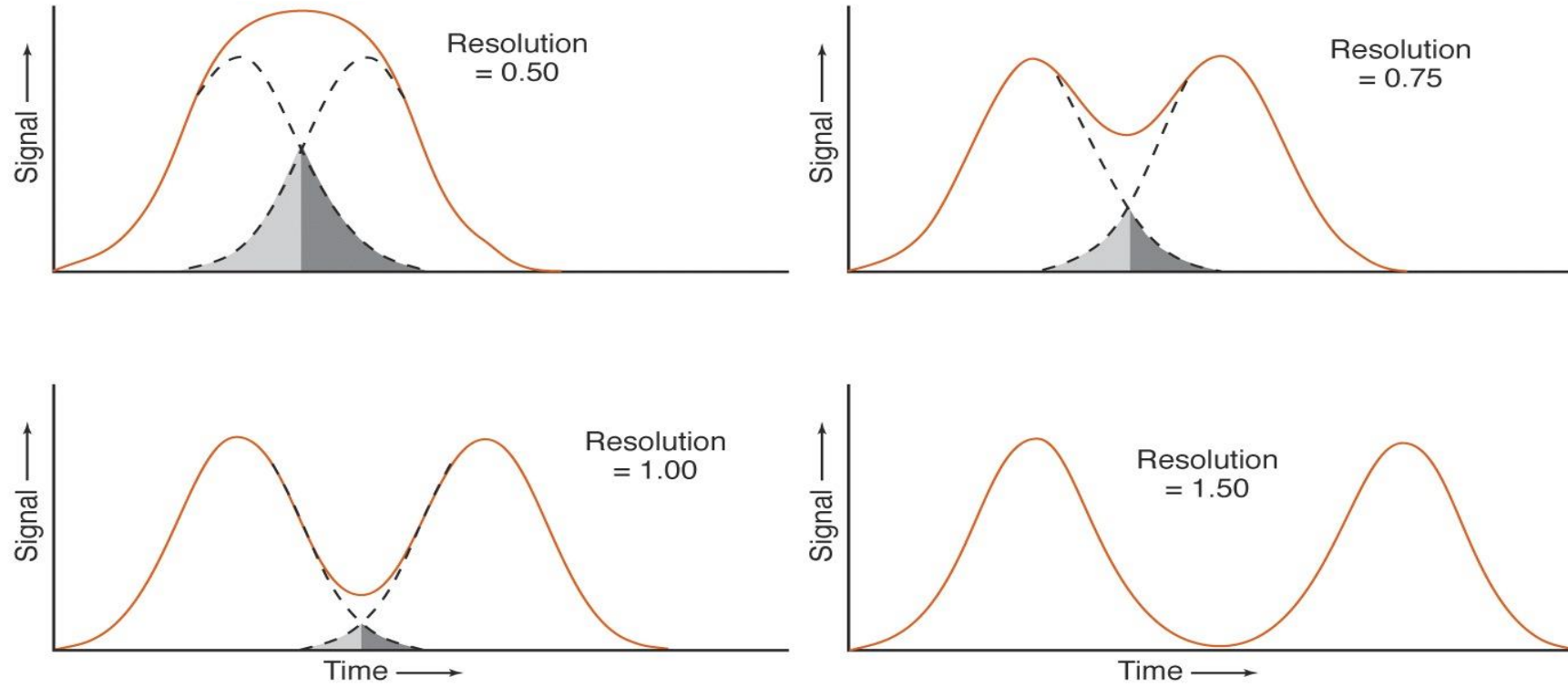

# Factors affecting resolution

1. Column length
2. Column diameter
3. Flow-rate
4. Uniformity of column packing
5. Uniformity of stationary phase (packing material)
6. Sample size
7. Suitability of stationary phase
8. Suitability of mobile phase
9. Pressure
10. Gradient elution

# Capacity

- Determines the size of column and system requirements for a given sample amount
- Saturation or equilibrium capacity – maximum amount of sample that will bind using the given mobile phase
- Measured by mixing a known amount of stationary phase with an excess of the analyte and measuring the bound versus free analyte
- There are also other methods for expressing column capacity *e.g.* dynamic capacity (which takes into account the flow on the column)
- When the capacity of the column is exceeded, asymmetric peaks are observed

# Asymmetric peaks

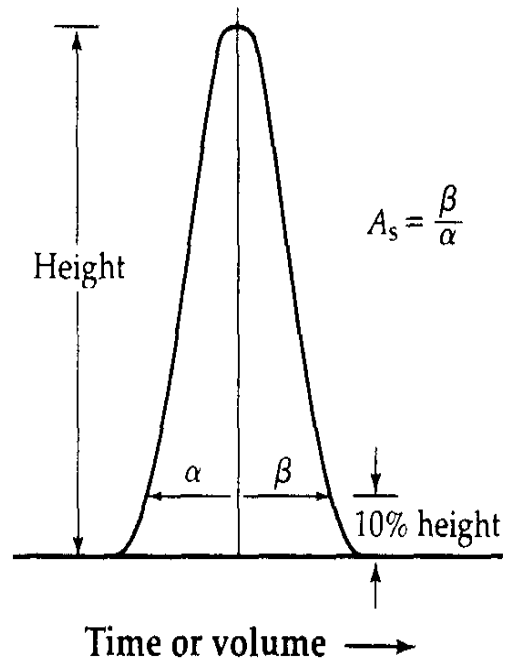

FIGURE 13.21 ▲  
Definition of the peak asymmetry factor  $A_s$ .

- Chromatographic parameters assume symmetric, Gaussian peaks
- Symmetric:  $A_s = 1.0$
- Tailing:  $A_s > 1.0$
- Fronting:  $A_s < 1.0$   
Fronting peaks are rare

# Asymmetric peaks

Tailing is usually due to overloading the column by adding too much sample

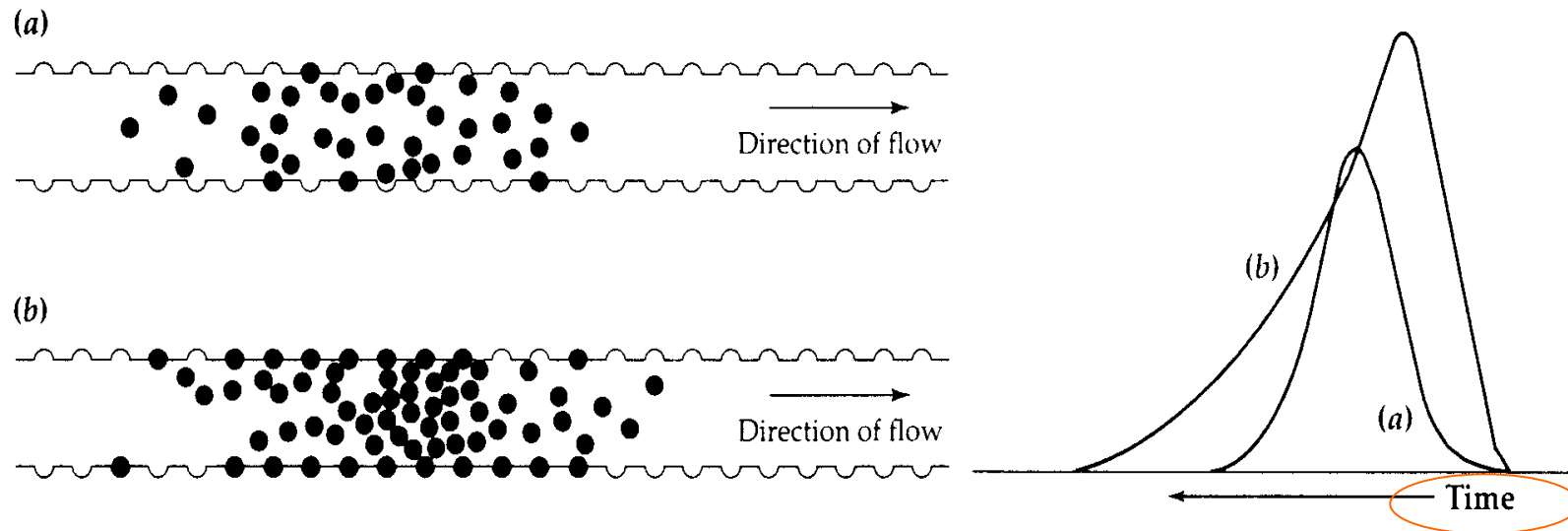
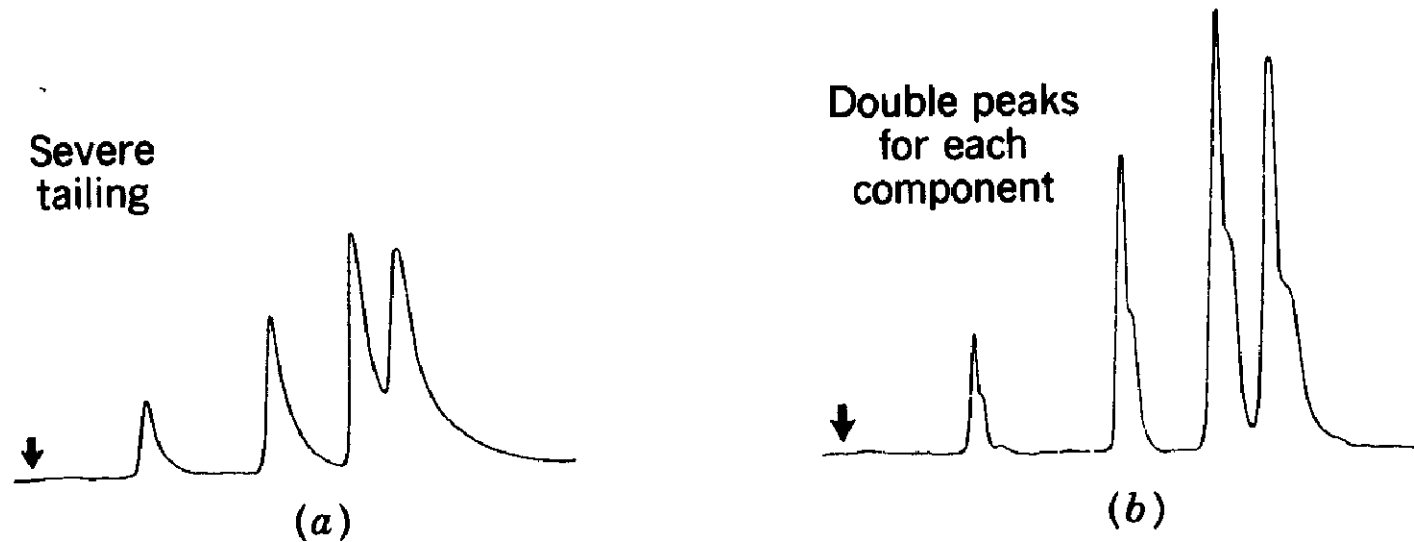

FIGURE 13.19 ▲  
Illustration of the effects of overloading a stationary phase in chromatography.

# Asymmetric peaks

Tailing and double peaks can also result from column void, a plugged inlet frit, and/or irreversible adsorption of analytes on the column



# Q2: Questions?

- What are some measures of chromatographic performance?
- What is resolution and what factors can affect it?
- What happens if too much sample is loaded on a column?

**Exercise:** Substances A and B have retention times of 6.4 and 14.4 min, respectively, on a 22.6 cm column. An unretained sample of air passed through the column in 1.30 min. The widths of the peak bases were 0.45 and 1.07 min. Calculate the:

1. The column resolution

2. The average number of plates

3. The plate height

Handwritten calculations on a piece of paper:

1.  $R_s = \frac{2 \times (14,4 - 6,4)}{0,45 + 1,07} = 10,5$

2.  $N_1 = 16 \left( \frac{6,4}{0,45} \right)^2 = 3236$        $N_2 = 16 \left( \frac{14,4}{1,07} \right)^2 = 2898$

$N_{\text{avg}} = \frac{N_1 + N_2}{2} = 3067$

3.  $H = \frac{L}{N} = \frac{22,6}{3067} = 7,36 \cdot 10^{-3} \text{ cm}$

# Liquid chromatography (LC)

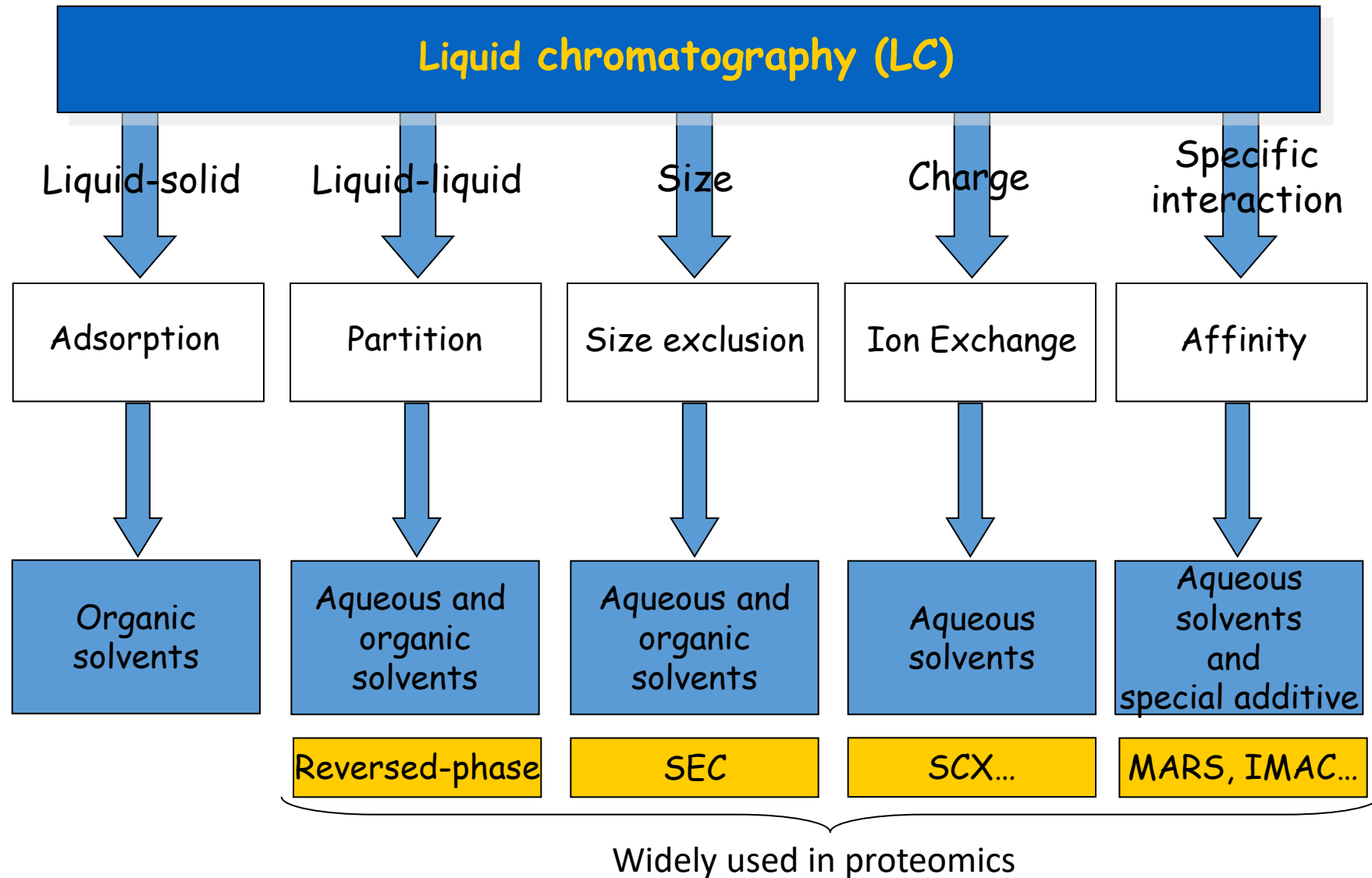

# Liquid chromatography (LC)

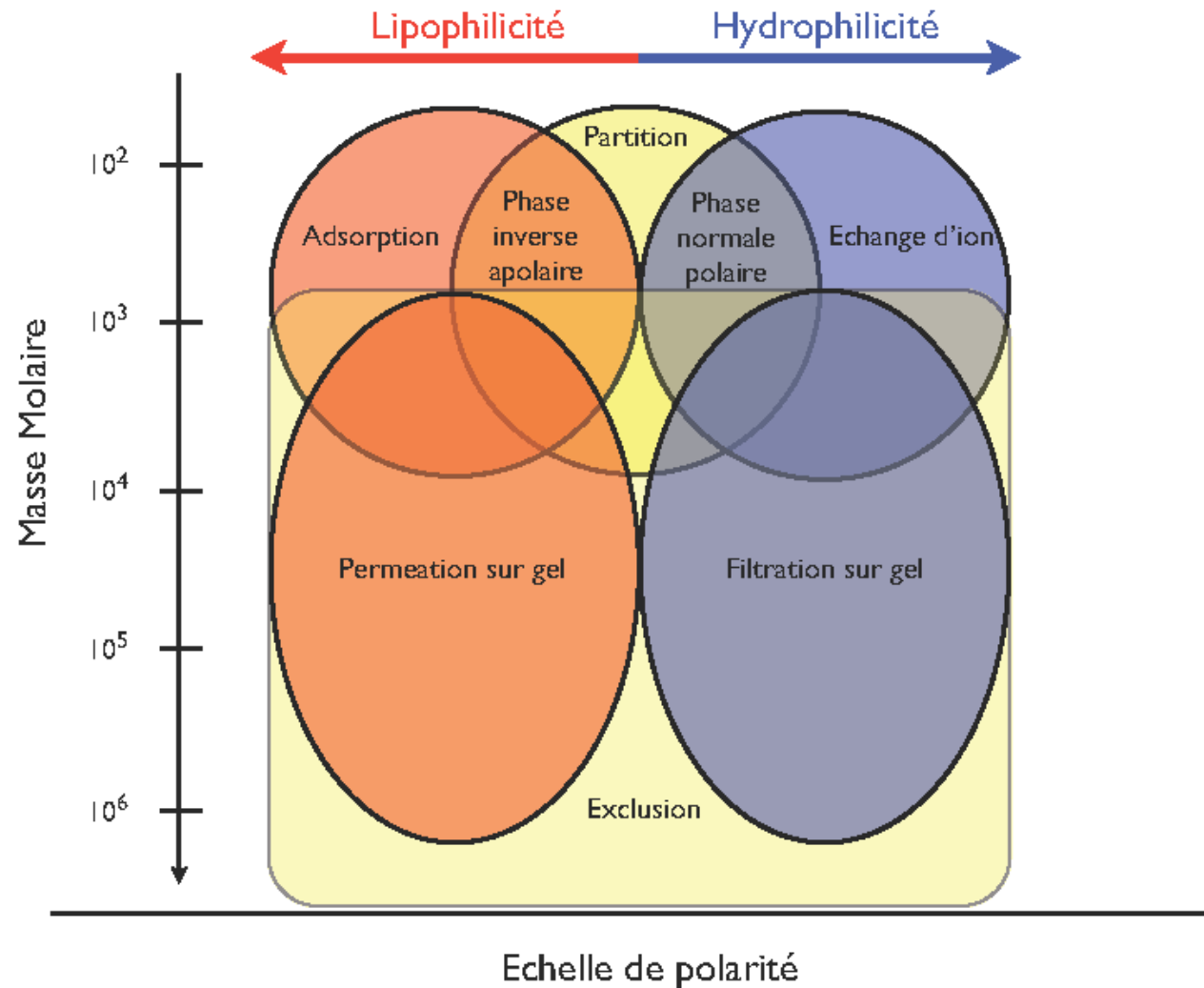

# Adsorption chromatography

Adsorption chromatography is probably one of the oldest types of chromatography around. It utilizes a mobile liquid that is adsorbed onto the surface of a stationary solid phase

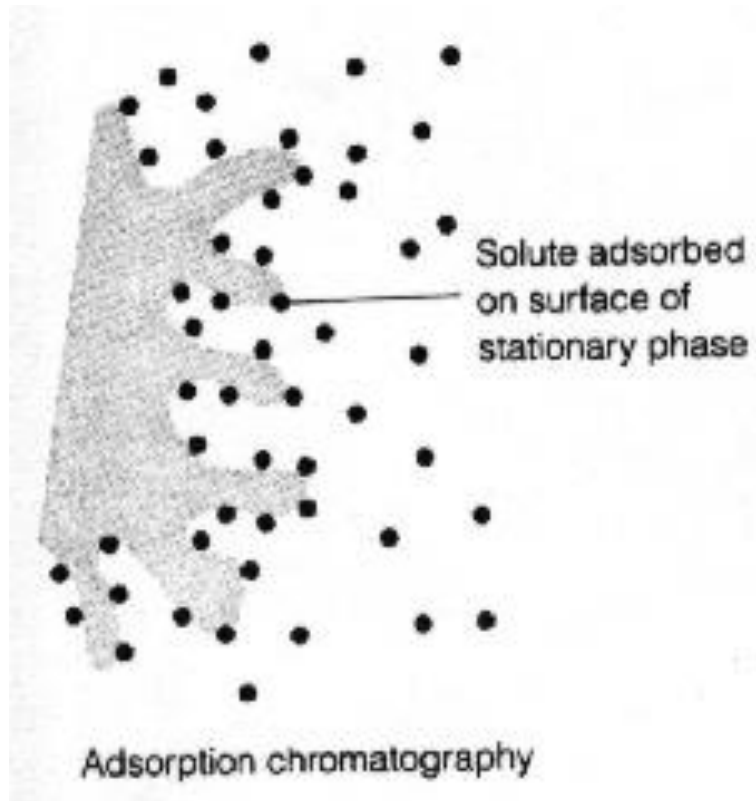

Adsorption chromatography is based mainly on differences between the adsorption affinities of the sample components for the surface of an active solid

# Adsorption chromatography

Normal-phase chromatography is based on an elution procedure in which the stationary phase is more polar than the mobile phase. This term is used in liquid chromatography to emphasize the contrast to reversed-phase chromatography.

- The most used polar adsorbents are:
- Silica (acidic)
  - Alumina (basic)

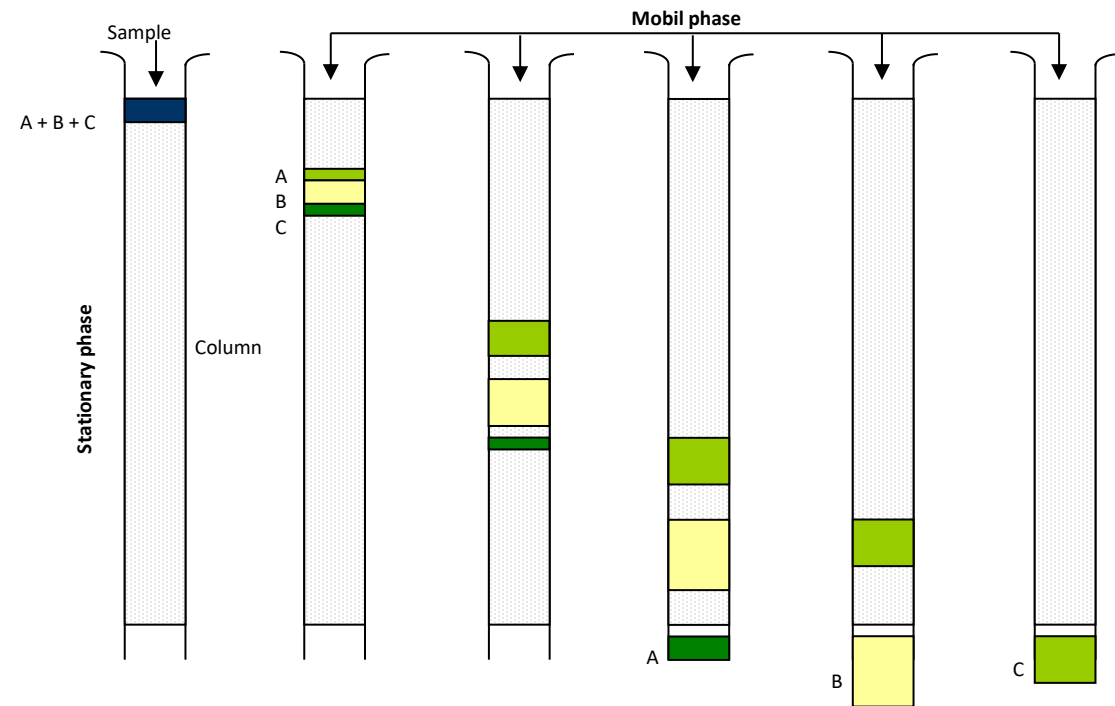

<http://www.iupac.org/goldbook/N04214.pdf>



# Reversed-phase (RP) chromatography

- Historically has been named “reversed-phase HPLC” because unlike “normal phase” chromatography it uses non-polar stationary phase and polar mobile phase
- RP-HPLC has quickly grown in its number of applications, and now it is the most widely used HPLC mode
- RP-LC exploits the differences of hydrophobicity of proteins and peptides

# Reversed-phase (RP) chromatography

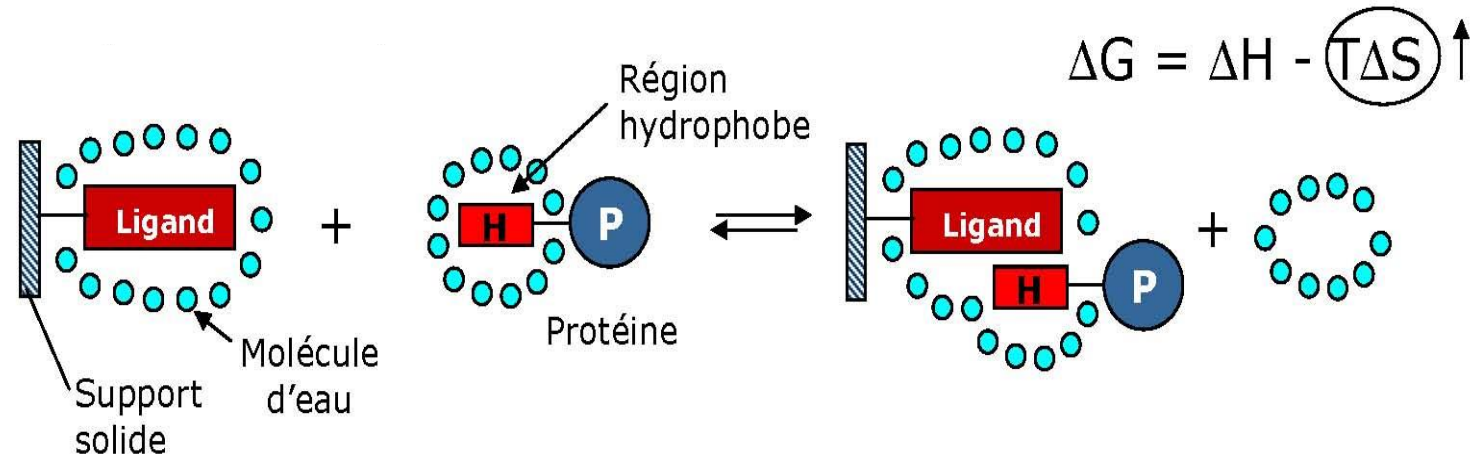

Water molecules at the ligand surface and the hydrophobic protein region are more organized than in solution

The displacement of the water molecules around the ligand surface and the hydrophobic protein region induces an increase of the entropy, that is thermodynamically favorable

# Reversed-phase (RP) chromatography

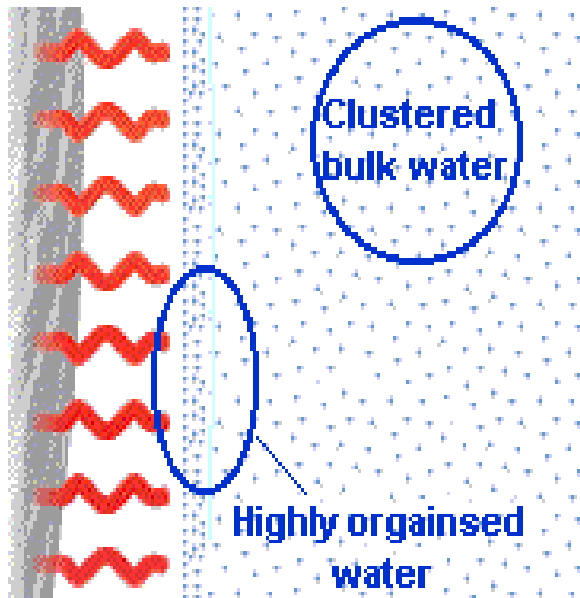

- Proteins are retained by the solid phase (silica carrying hydrophobic groups (C4, C8, C18)) according to their hydrophobicity

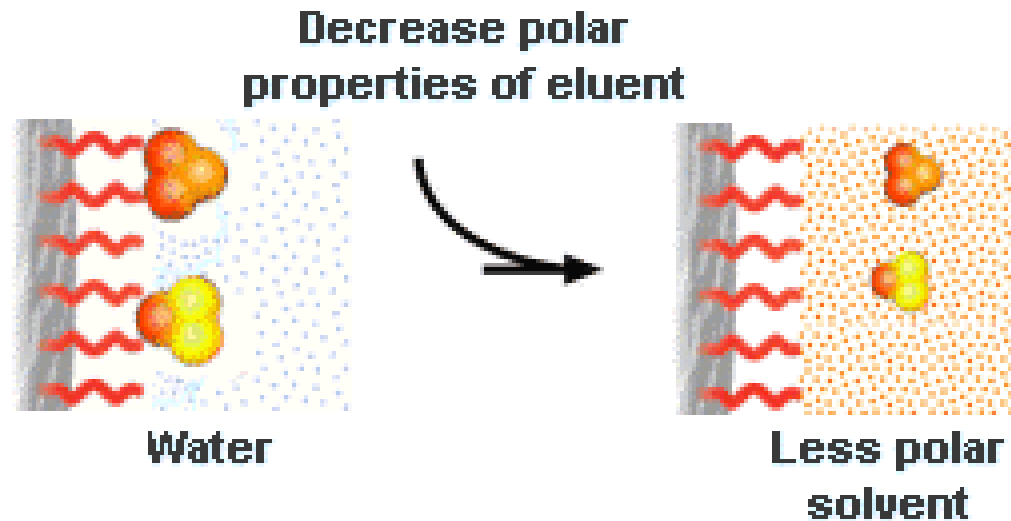

# Reversed-phase (RP) chromatography

- When solvent is very polar all proteins will be captured (solvent polarity drives hydrophobic interactions)
- As polarity decreases, proteins are eluted from the column according to hydrophobicity (least hydrophobic first)

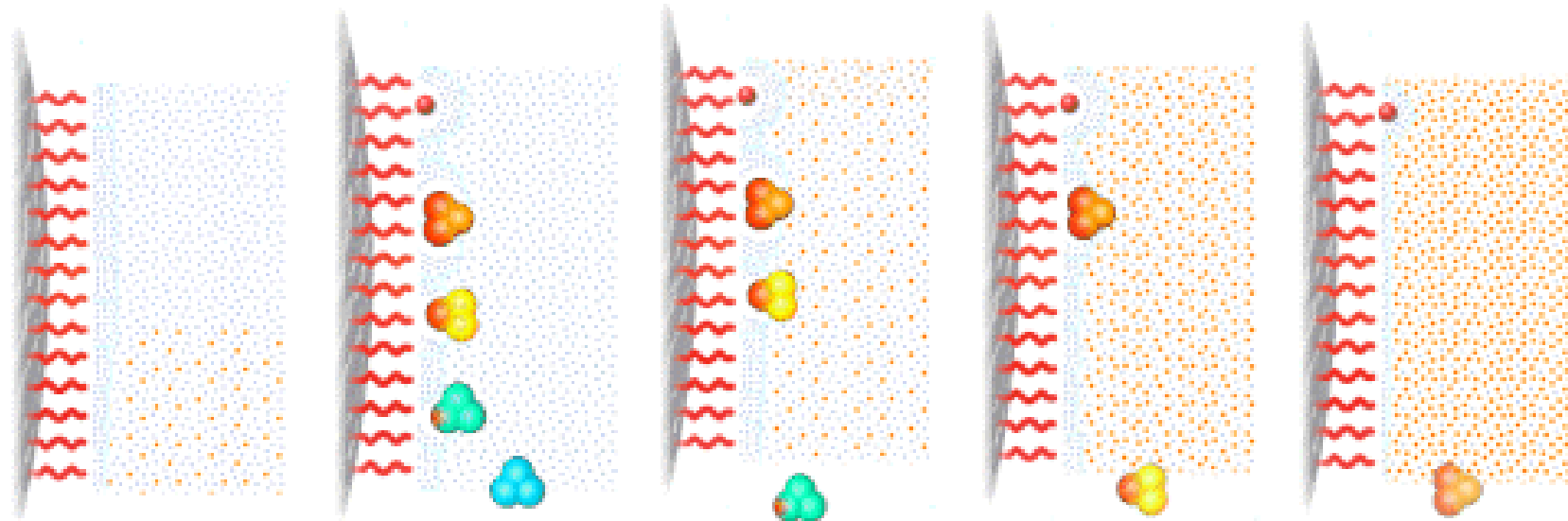

# Reversed-phase (RP) chromatography

<b>Organic modifier</b>	<b>Suitable for:</b>	<b>UV cut-off</b>	<b>Viscosity</b>	<b>Comments</b>
Methanol	Org. molecules	210	Medium- low	May destabilize protein structure
Ethanol	Org. molecules	205	Medium- low	May destabilize protein structure
Isopropanol	Proteins Peptides	210	High	Least effect on protein structure
<b>Acetonitrile (CH<sub>3</sub>CN)</b>	Org. molecules Proteins Peptides	190	Low	Less effect on Protein structure

# Bonding type

- Monomeric bonding offers increased mass transfer rates, higher column efficiency, and faster column equilibration
- Polymeric bonding offers increased column stability, particularly when highly aqueous mobile phases are used
- Polymeric bonding also enables the column to accept higher sample loading

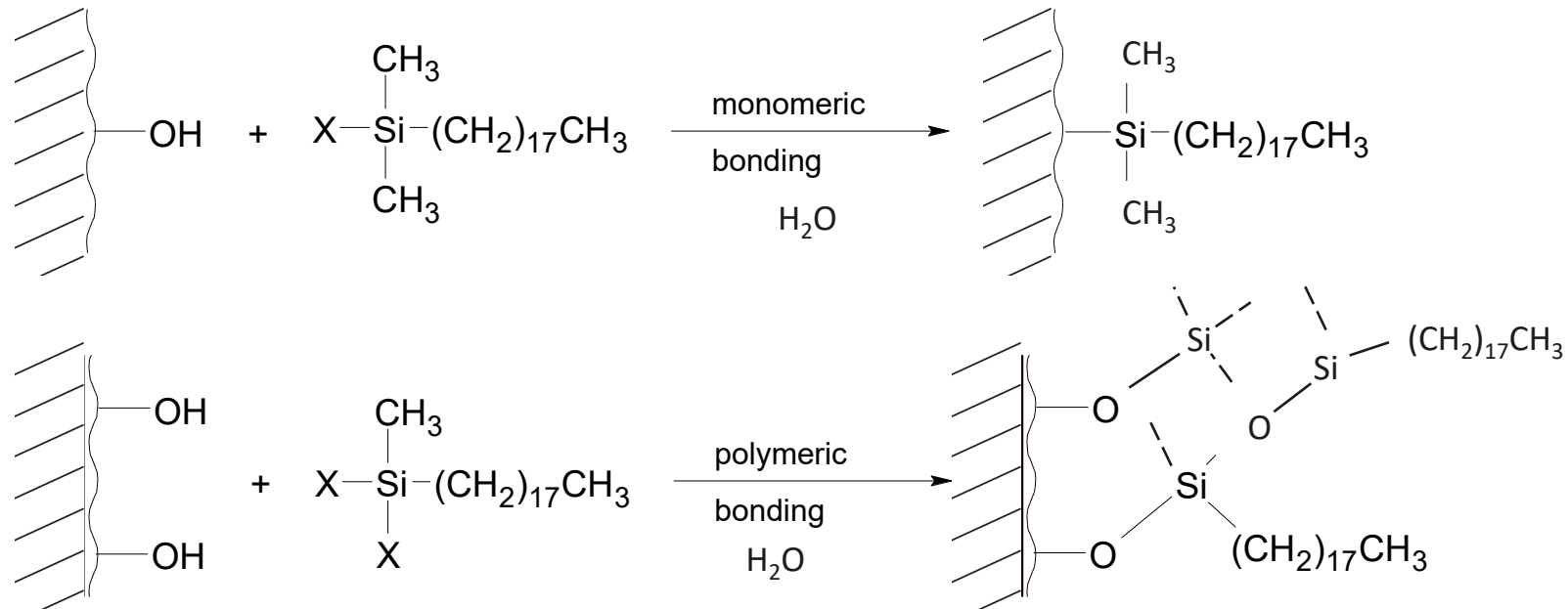

# Carbon load

- Higher carbon loads generally offer greater resolution and longer run times
- Low carbon loads shorten run times and many show a different selectivity

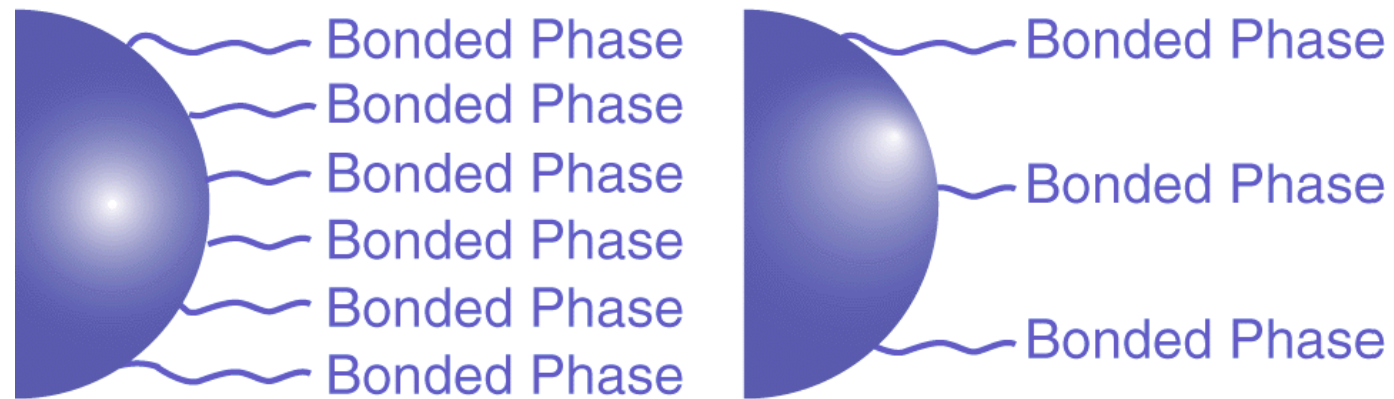

# Endcapping

- Definition: blocking remaining free silanols of silica following attachment of alkyl chains
- Endcapping reduces peak-tailing of polar solutes that interact excessively with the otherwise exposed, mostly acidic silanols
- Non-endcapped packings provide a different selectivity than do endcapped packings, especially for such polar samples

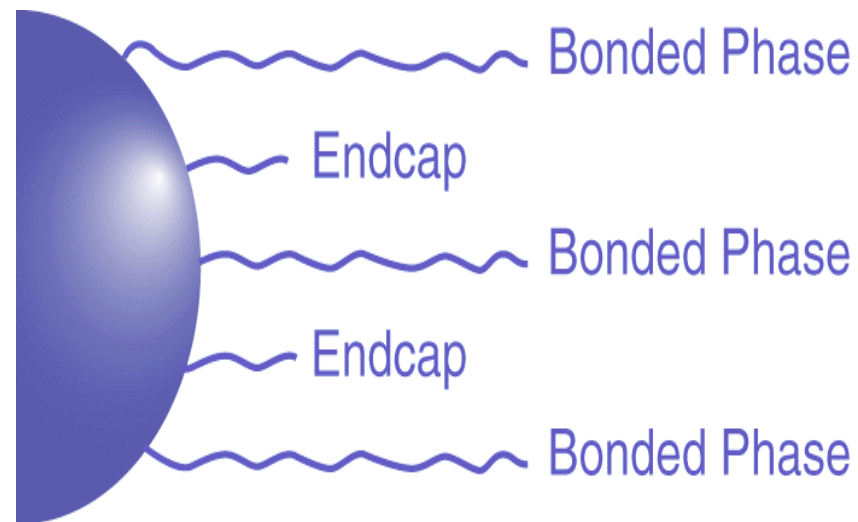

# Particles

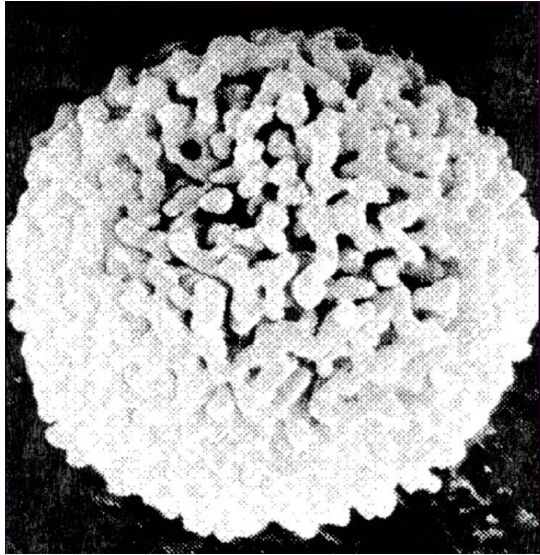

**Size** (smaller particles give higher efficiency but require higher operating pressures)

- usually 3-10  $\mu\text{m}$  for analytical HPLC separations
- 10-40  $\mu\text{m}$  for preparative HPLC
- 40-150  $\mu\text{m}$  for low pressure or large scale preparations

**Pore** (pore size defines an ability of the analyte molecules to penetrate inside the particle and interact with its inner surface) General guide:

- Choose a pore size of 150  $\text{\AA}$  or less for sample  $MW < 2000$
- Choose a pore size of 300  $\text{\AA}$  or greater for sample  $MW > 2000$

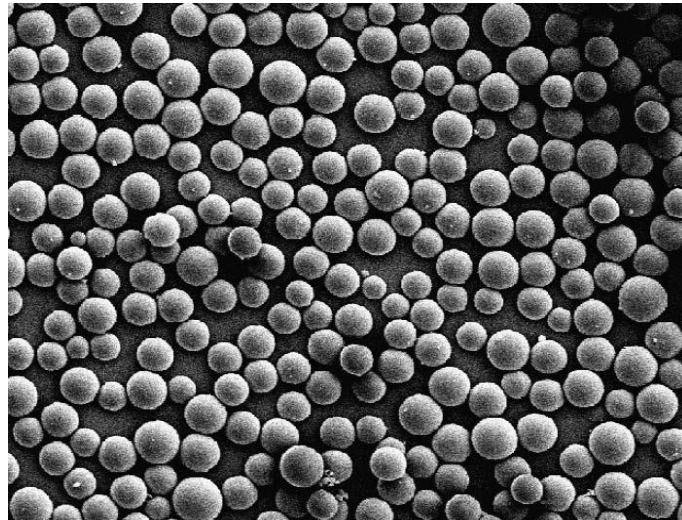
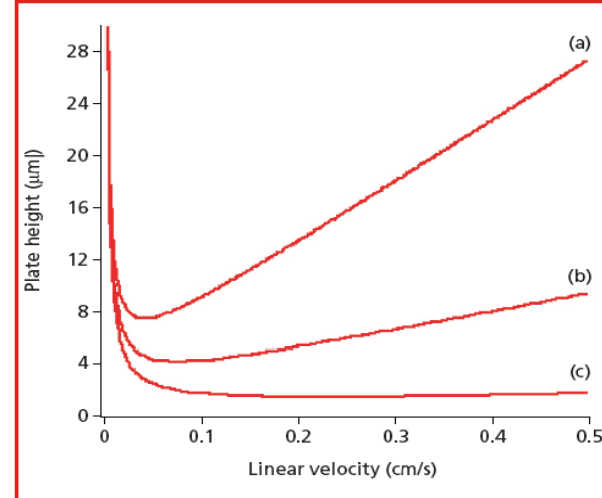

Figure 1: Theoretical performance of columns packed with (a) 5  $\mu\text{m}$ , (b) 3  $\mu\text{m}$  and (c) 1  $\mu\text{m}$  particles.



Van Deemter curves

# Gel filtration - size exclusion chromatography (SEC)

- Separates proteins according to their size and shape
- Separation depends upon differences in the ability of different proteins to gain access to pores in the resin beads

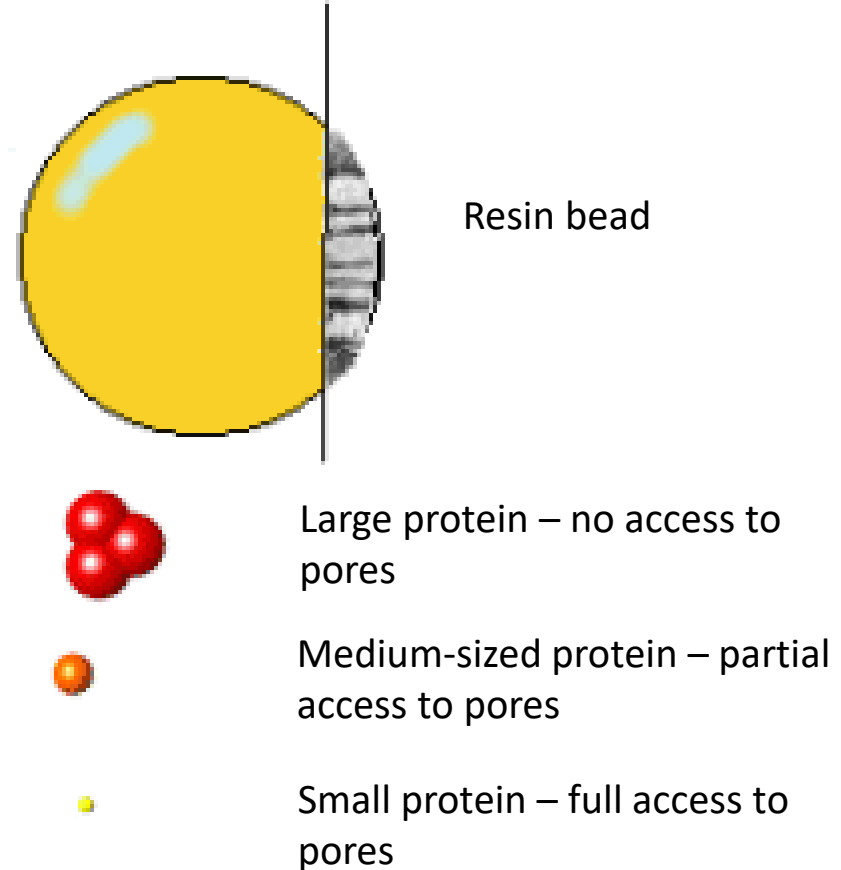

# Gel filtration - size exclusion chromatography (SEC)

- Larger molecules have a lower volume to diffuse through, so they are eluted more rapidly than smaller molecules

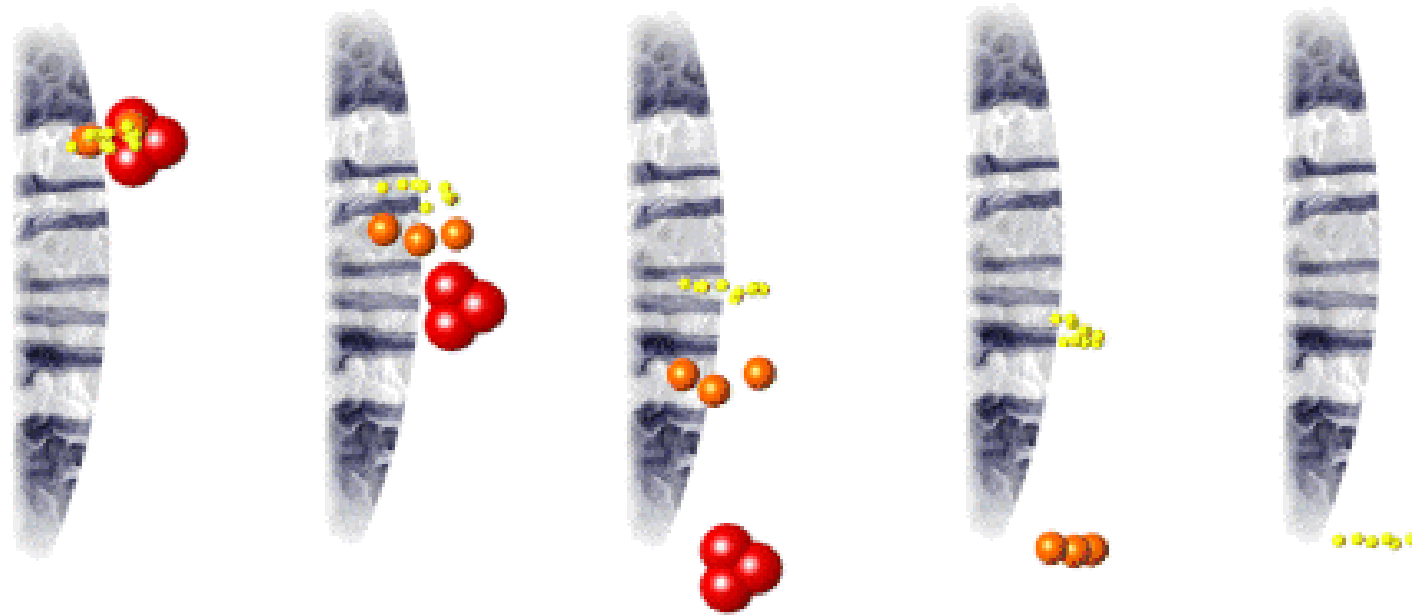

# Ion exchange chromatography (IEC)

- is a process that allows the separation of ions and polar molecules based on their charge properties
- IEC retains analyte molecules based on coulombic (ionic) interactions
- The stationary phase surface displays ionic functional groups that interact with analyte ions of opposite charge
- Cation exchange chromatography retains positively charged cations because the stationary phase displays a negatively charged functional group such as a phosphonic acid
- Anion exchange chromatography retains negatively charged anions using positively charged functional group such as a quaternary ammonium cation

# Ion exchange chromatography (IEC)

- Based on the net surface charge of the protein.
- This will depend on the protein's isoelectric point and the pH of the solution (buffer) used for the chromatography.

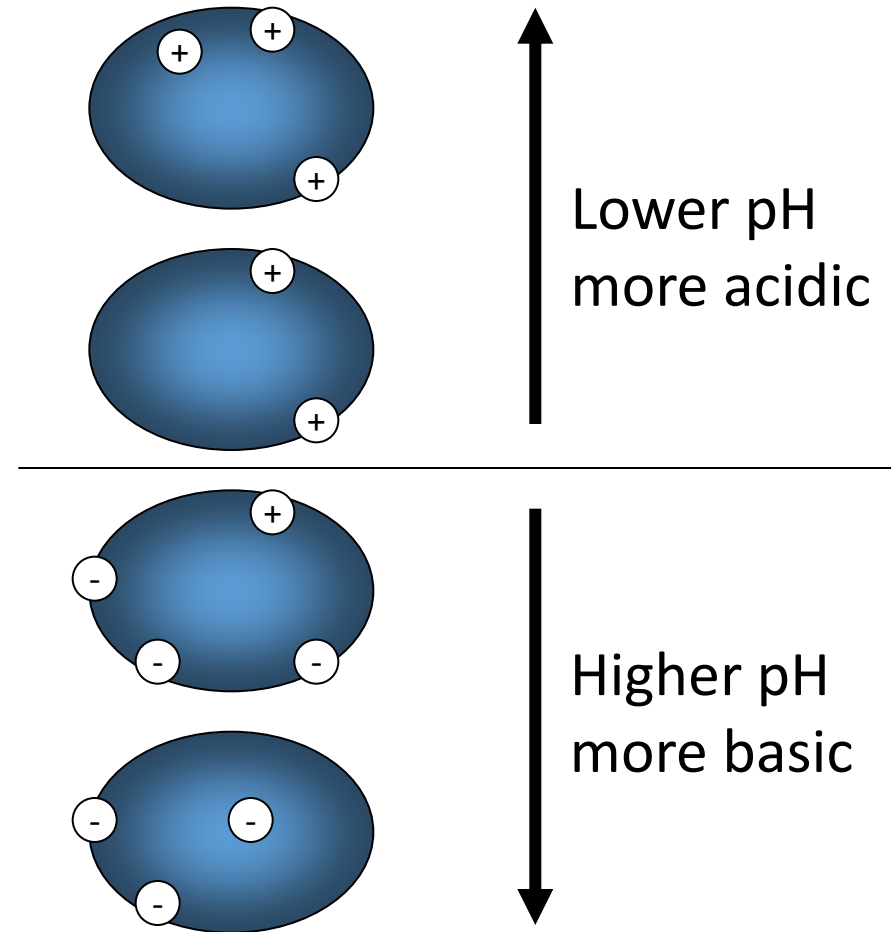

# Ion exchange chromatography (IEC)

- In this example, negatively charged proteins bind to a positively charged resin
- They can be eluted by adding an excess of salt – the anion competes with the protein for positive charges on the solid phase thus displacing it

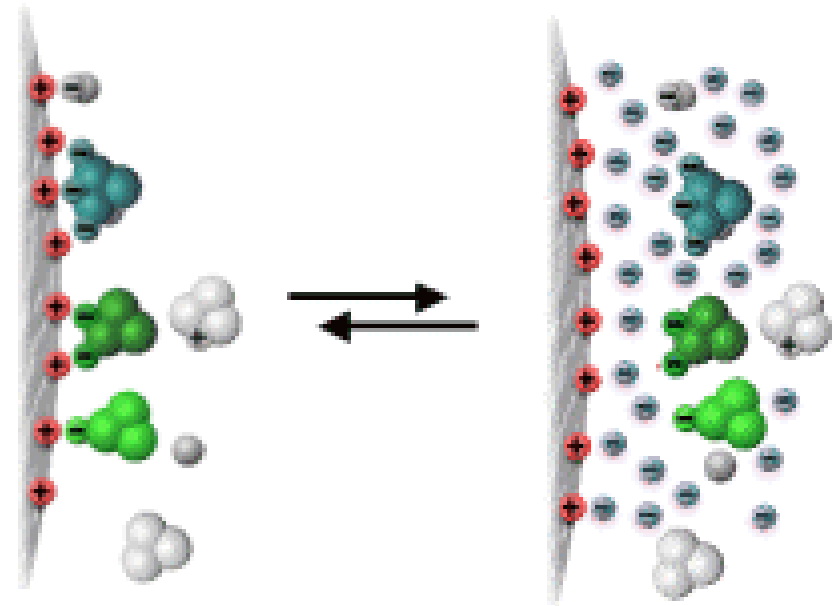

# Ion exchange chromatography (IEC)

- Proteins that carry more negative charges have higher affinity for the positively charged surface.

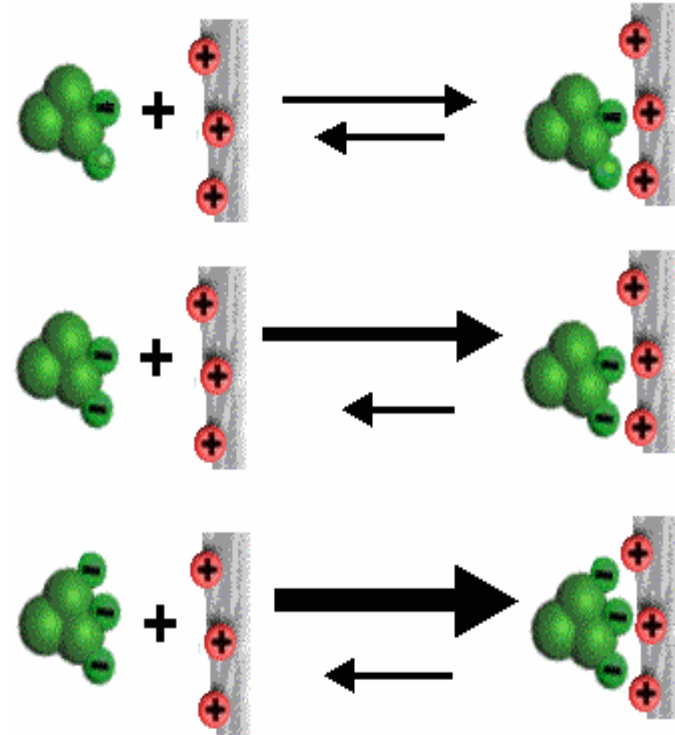

# Ion exchange chromatography (IEC)

- Lower salt concentrations are required to elute the less charged proteins from the column.

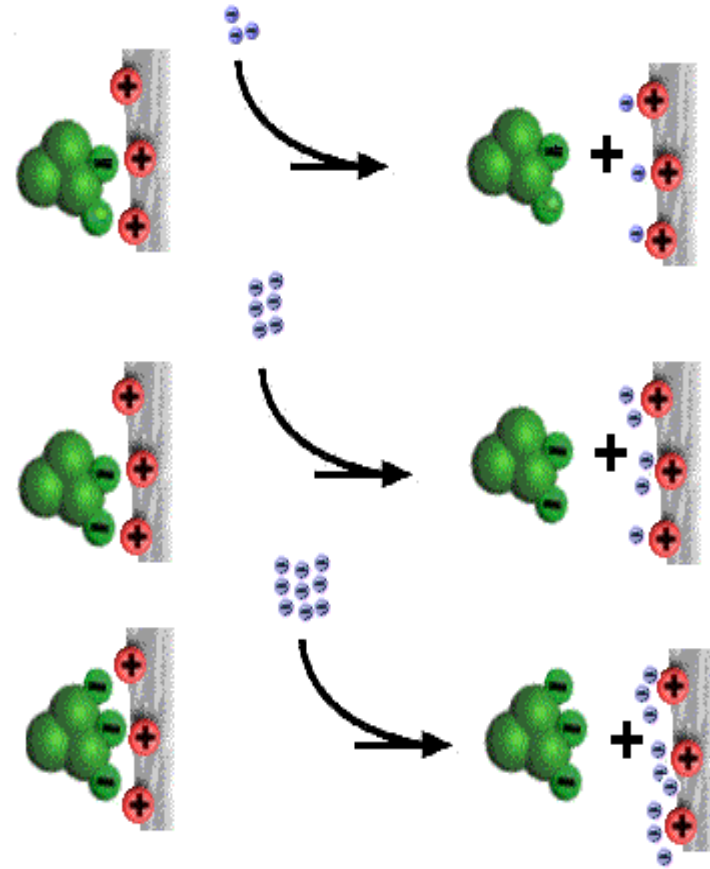

# Ion exchange chromatography (IEC)

- Gradient elution (increasing salt concentration) allows sequential elution of proteins according to their surface charge.

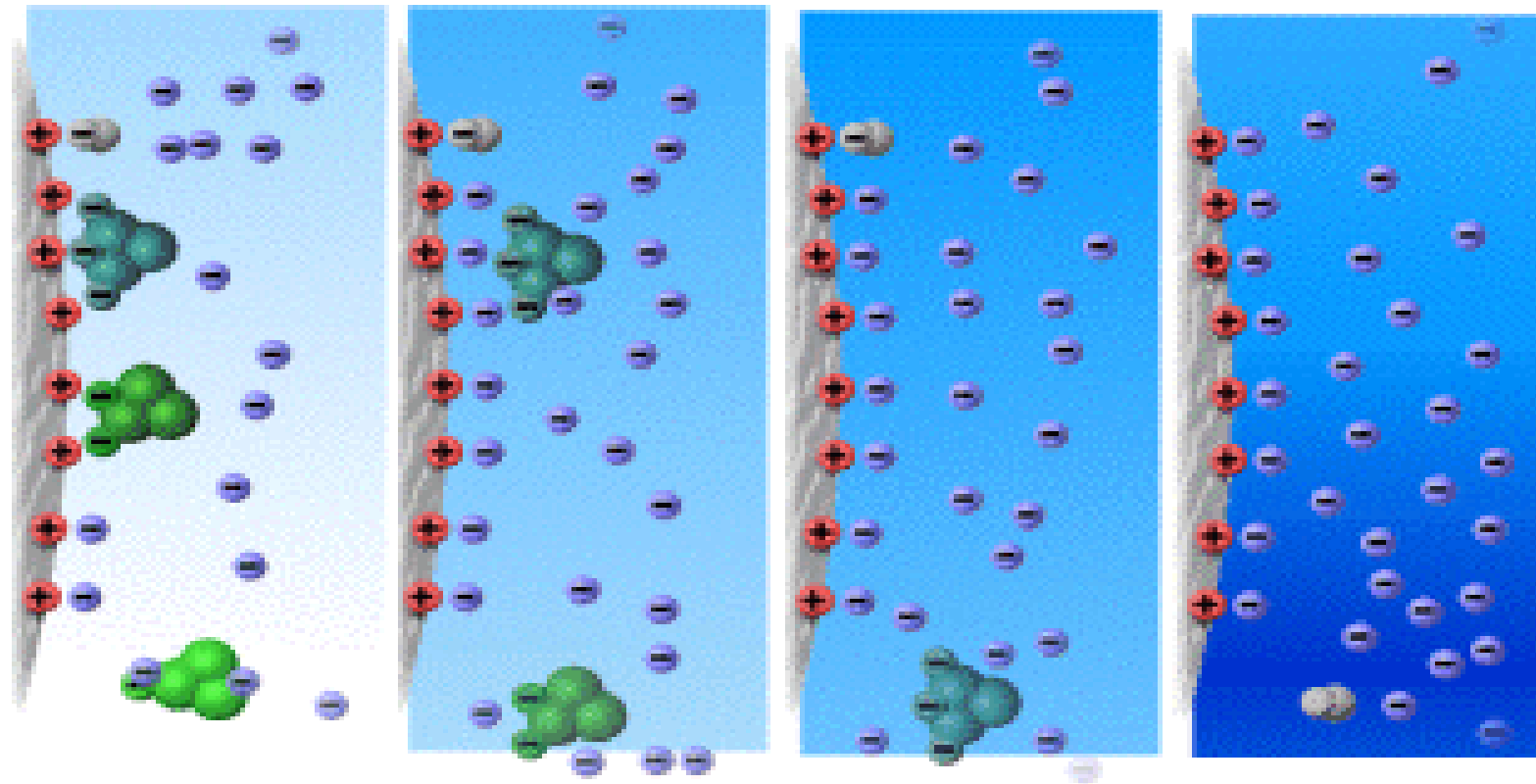

# Ion exchange chromatography (IEC)

- Relatively low specificity
- Resin has high binding capacity
- Elution conditions are mild – unlikely to damage proteins

Anion exchangers	Functional group
Diethylaminoethyl (DEAE)	$-O-CH_2-CH_2-N^+H(CH_2-CH_3)_2$
Quaternary aminoethyl (QAE)	$-O-CH_2-CH_2-N^+(C_2H_5)_2-CH_2-CHOH-CH_3$
Quaternary ammonium (Q)	$-O-CH_2-CHOH-CH_2-O-CH_2-CHOH-CH_2-N^+(CH_3)_3$

Cation exchangers	Functional group
Carboxymethyl (CM)	$-O-CH_2-COO^-$
Sulfopropyl (SP)	$-O-CH_2-CHOH-CH_2-O-CH_2-CH_2-CH_2-SO_3^-$
Methyl sulfonate (S)	$-O-CH_2-CHOH-CH_2-CH_2-CHOH-CH_2-SO_3^-$

# Off-gel IEF *versus* SCX chromatography

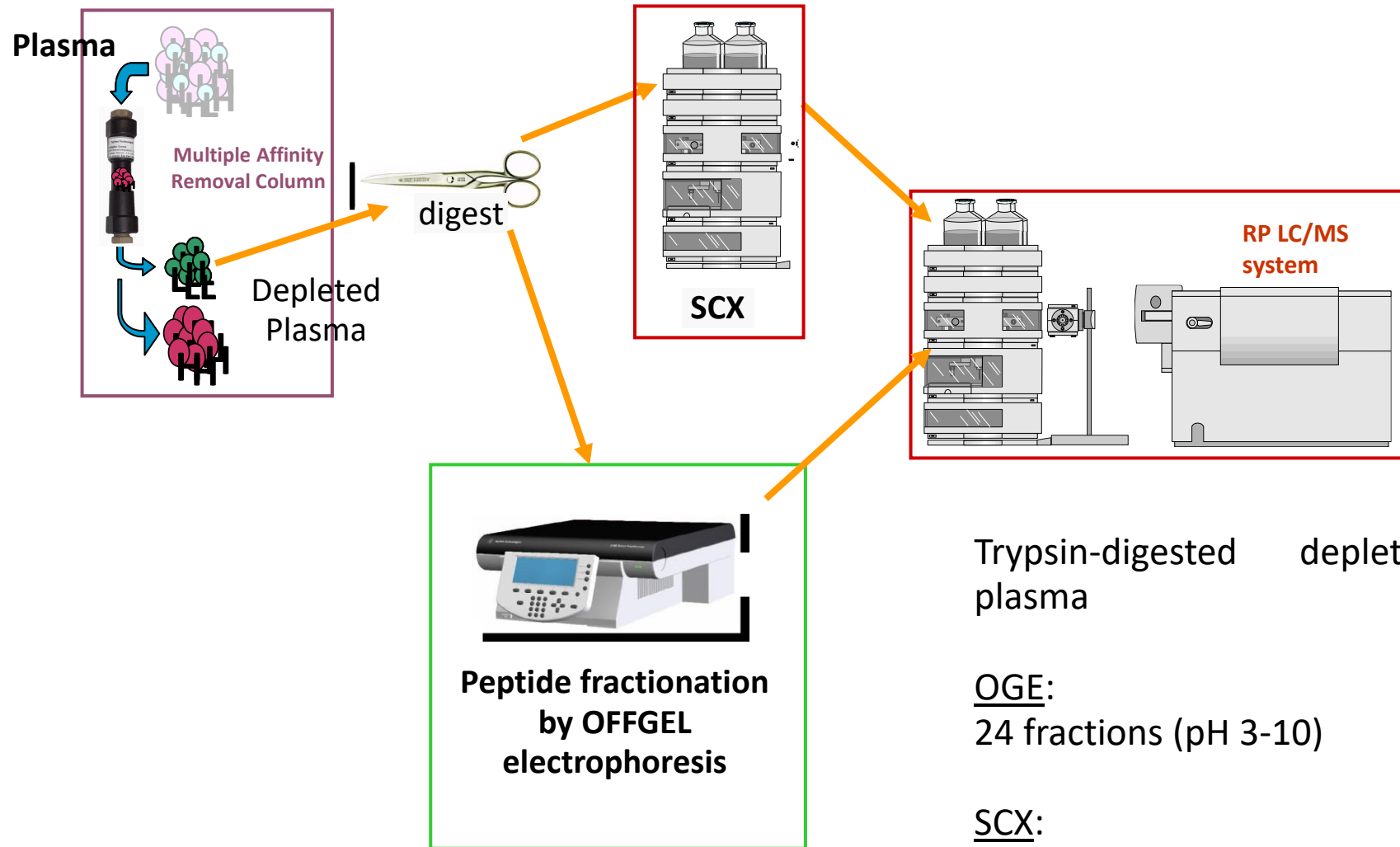

Trypsin-digested depleted plasma

OGE:  
24 fractions (pH 3-10)

SCX:  
50 fractions

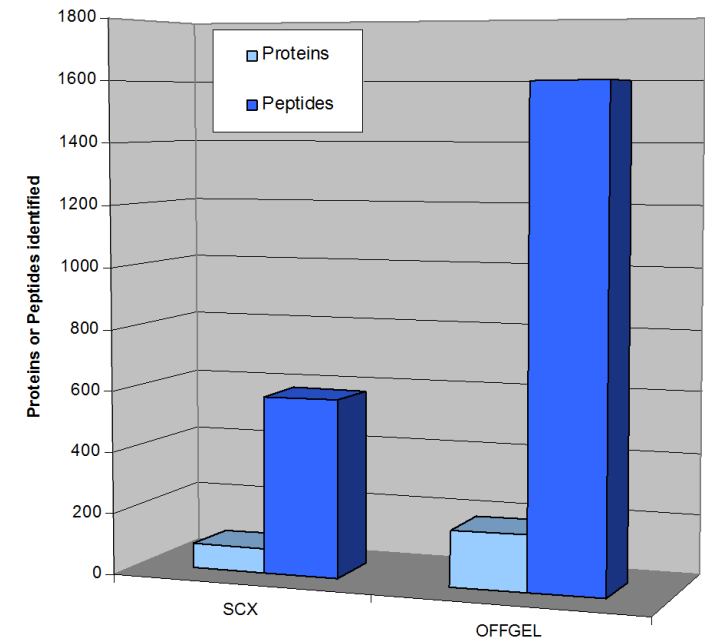

# Off-gel IEF *versus* SCX chromatography

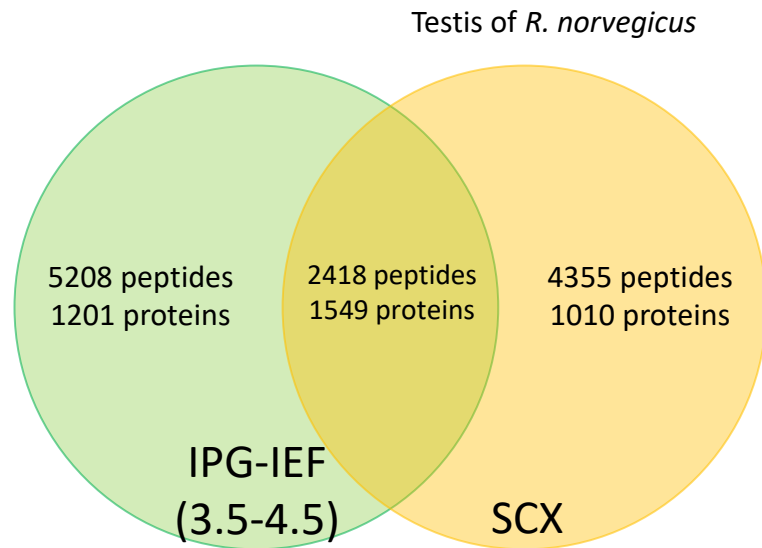

Cargile et al., *J. Biomol. Tech.*, 2005, 16(3), 181–189

- Comparison of narrow range IPG IEF (pH 3.5-4.5) with off-line strong-cation exchange chromatography
- 13% more proteins with IEF, less fractions to analyze with LC MS (43 vs. 128)
- **Complementarities for in depth proteome coverage**

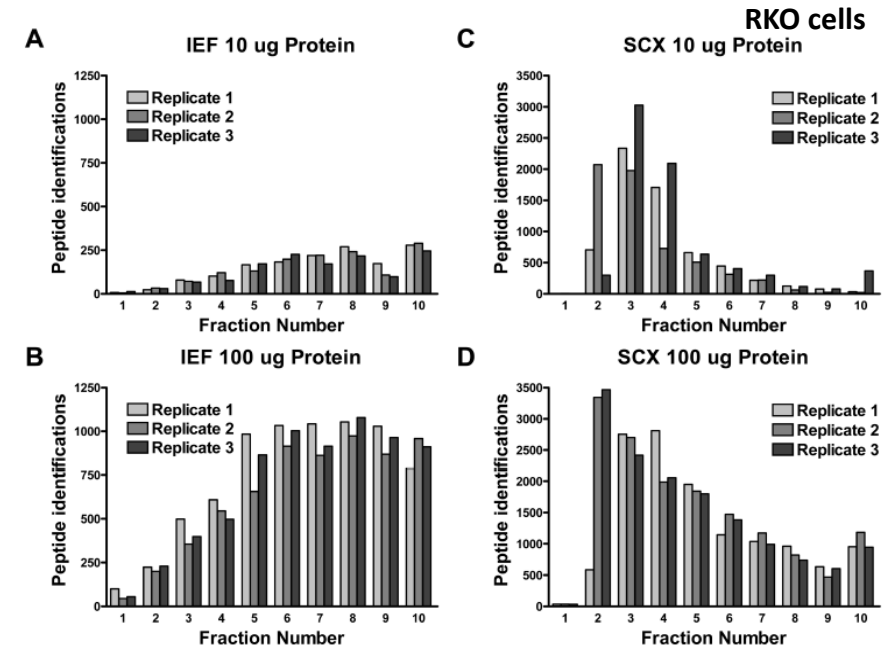

Slebos et al., *J. Proteome Res.* 2008, 7, 5286-6294

- Greatest number of peptides and proteins with SCX-based platform (twice more for low sample amount (10  $\mu$ g))
- **Greatest reproducibility with IEF platform**
- **Greatest resolution with IEF platform** (90% of all peptides found in a single fraction)

# Off-gel IEF *versus* SCX chromatography

Membrane-enriched fraction from murine C2C12 cells

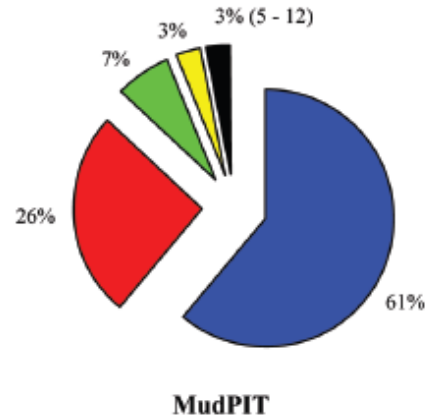
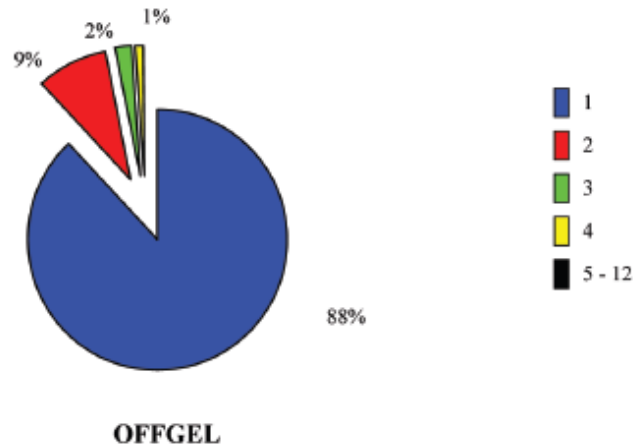
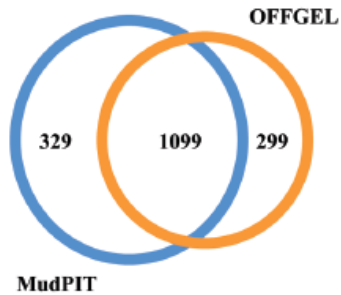
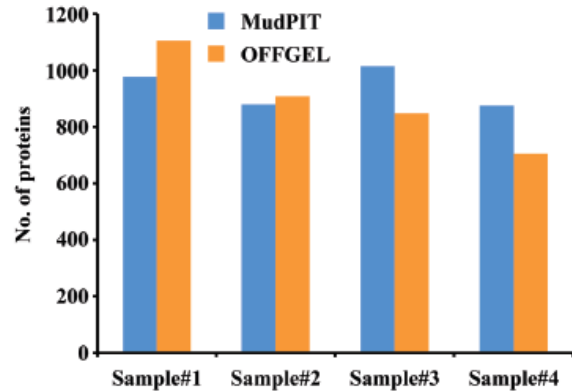

- Comparable in terms of protein identifications (12 vs. 12 fractions)
- Off-gel 88% peptides in a single fraction vs. SCX 61% => **superior focusing quality of IEF**
- Sample complexity (off-gel superior to SCX for a more complex sample (HEK cell lysate)), 3143 vs. 2242 proteins

- **Proteome coverage apparently depends on peptide amounts and sample complexity**

- But all agree for:**
- **Superior resolution of peptide IEF**
  - **Better reproducibility**

# Affinity chromatography

- Makes use of a highly specific interaction between a target protein and a ligand on the solid phase.
- *e.g.*.. antibody on column, antigen tag on protein
- *e.g.*.. glutathione on column, target protein as GST-fusion

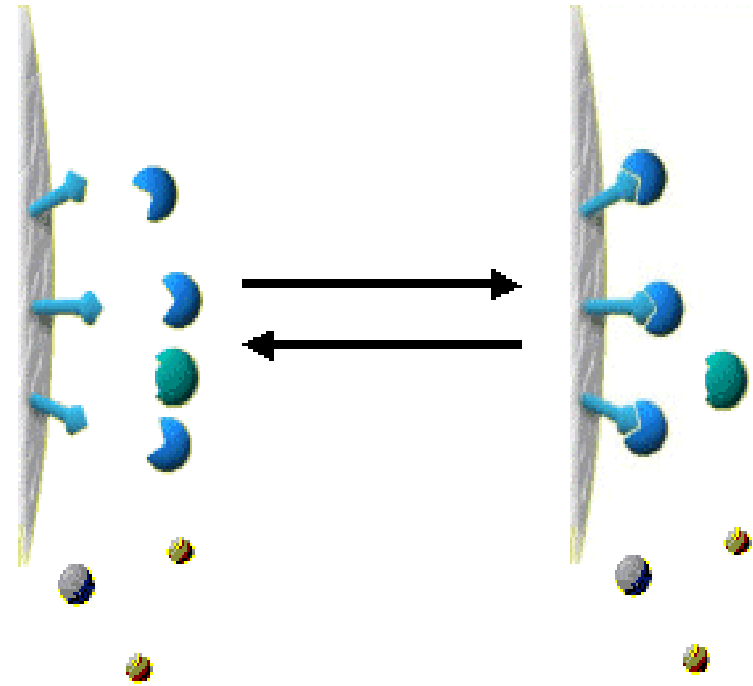

# Affinity chromatography

- Affinity resin captures the target with high specificity
- Elution can be performed by mild denaturation

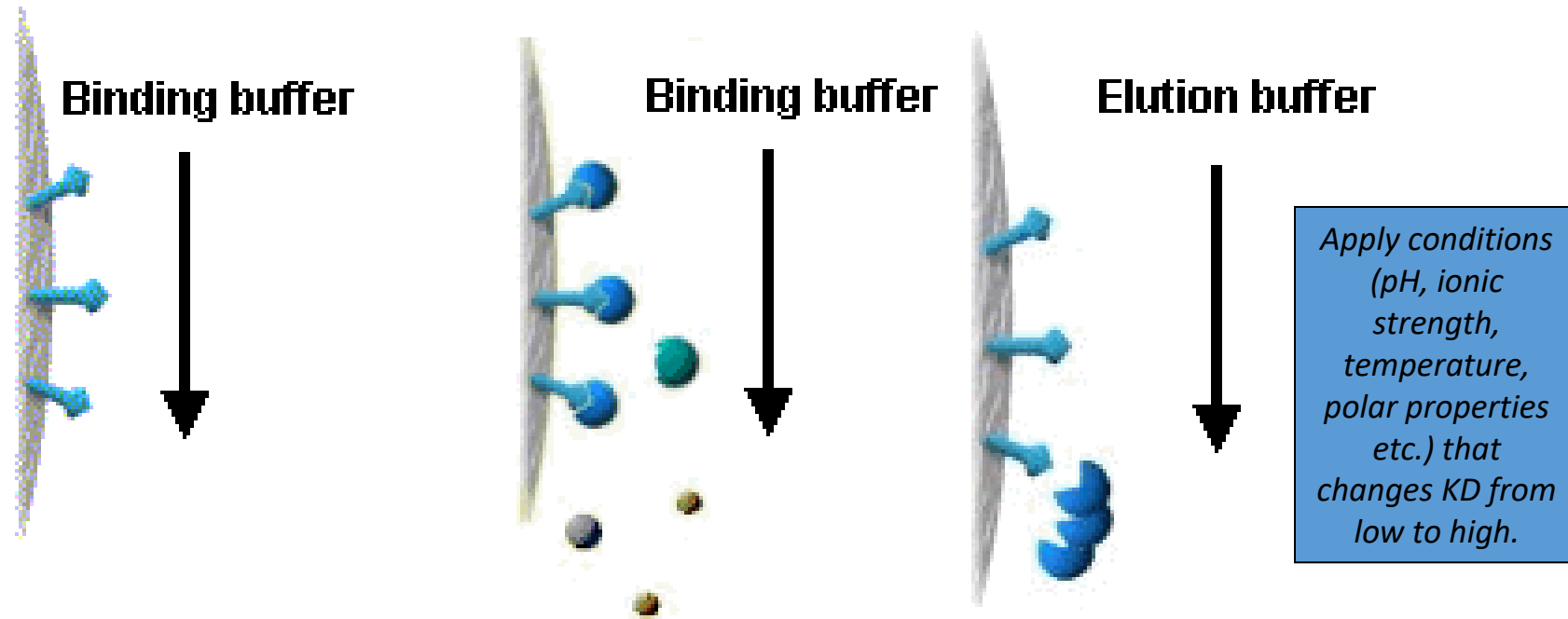

# Affinity chromatography

- Affinity resin captures the target with high specificity

- or by a soluble competitor

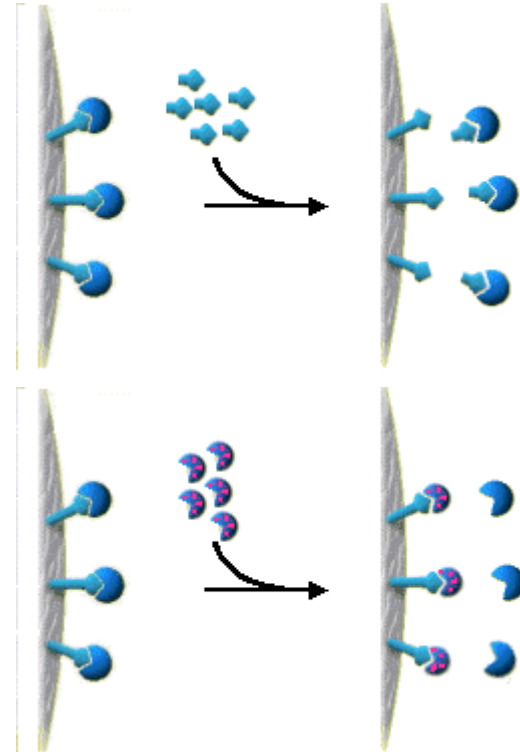
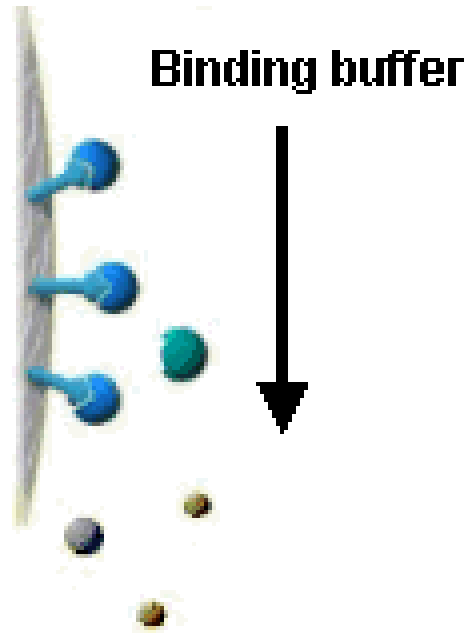
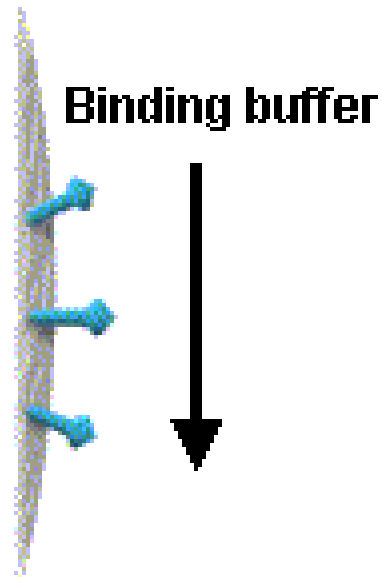

# Immobilised metal affinity chromatography (IMAC)

- Immobilised metal chelating group (*e.g.* imidodiacetate) with a bound multivalent transition metal
- The metal ion ( $\text{Cu}^{2+}$ ,  $\text{Zn}^{2+}$ ,  $\text{Ni}^{2+}$ ,  $\text{Co}^{2+}$  or  $\text{Fe}^{2+}$ ) is bound so that at least one coordination site is available for interaction with proteins or peptides
- Proteins with affinity to metal ions can be bound to the column and subsequently eluted by change of conditions
- Not many naturally occurring proteins have affinity for metal ions so it is [very specific](#)
- Technique is mainly used to purify recombinant proteins expressed with N-terminal Histidine-tag (His-Tag)
- Elution is generally performed using imidazole (2), which competes for the metal site with histidine (1) and releases the protein

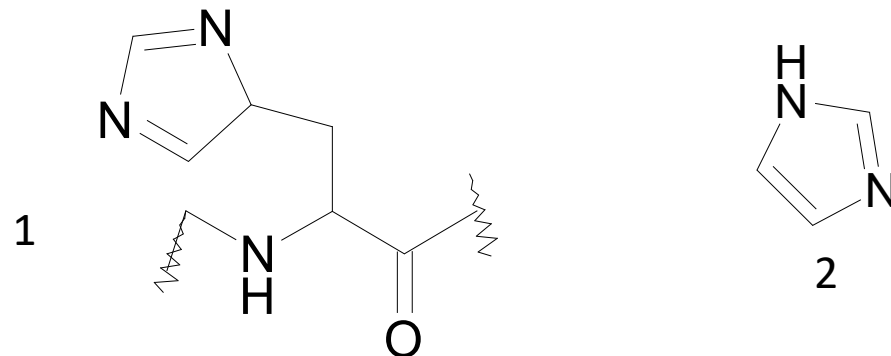

# Affinity chromatography

- High specificity
- Low capacity
- Denaturing elution can damage protein

<b>Group-specific separations</b>
<ul style="list-style-type: none"><li>• Glycoproteins</li><li>• IgG antibodies</li><li>• Enzymes</li><li>• Proteins/peptides with accessible histidines</li></ul>

<b>Mono-specific separations</b>
<ul style="list-style-type: none"><li>• Antigens</li><li>• Antibodies</li><li>• Hormones</li><li>• Receptors</li><li>• Enzymes</li><li>• Tagged recombinants</li></ul>

Three groups of properties of the target molecule are used in affinity chromatography:

## 1. Specific binding properties based on biological activity like:

- Enzyme active sites
- Receptor binding sites
- Antibody binding sites etc

These are used together with the natural ligand or an analogue of it. Sometimes the analogue has a broader specificity and can be used for group separations

## 2. Naturally occurring prosthetic groups like:

Polysaccharides etc

Such properties normally allow group separations only

## 3. Molecules equipped with an affinity tag like:

Glutathione-S-Transferase (GST)

- Oligo histidine etc

This group of properties is used almost exclusively for recombinant fusion proteins

# High performance LC (HPLC)

- High Performance Liquid Chromatography ([HPLC](#)) is the most widely used analytical technique
- In the column, the mixture is resolved into its components. The amount of [resolution](#) is important, and is dependent upon the extent of interaction between the solute components and the stationary phase
- The interaction of the solute with mobile and stationary phases can be manipulated through different choices of both solvents and stationary phases
- As a result, HPLC acquires a high degree of versatility not found in other chromatographic systems and it has the ability to easily separate a wide variety of chemical mixtures

# High performance LC (HPLC): Components (1)

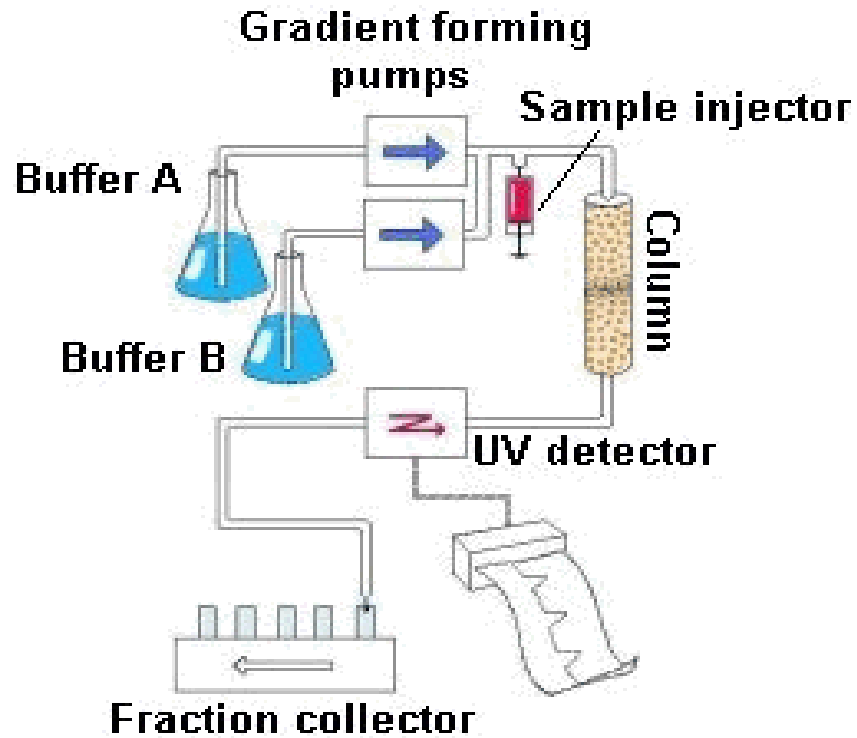

1. [Solvent](#) Reservoir- Glass bottles or flasks with:

- Tubing to pump
- Filter at tubing entrance to remove particles
- Gas line to purge dissolved gases (or vacuum degasser)
- Solvent

2. [Pump](#)

- To aspirate the mobile phase & force it through the column & detector
- Operate in two modes:
  - Isocratic: single solvent
  - Gradient: change solvent stepwise or continuous

3. [Injectors](#)

- To introduce sample into column
- Sample loop injector
- Manual injection or automatic injection using autosampler

# High performance LC (HPLC): Components (2)

## 4. [Column](#)

- Chosen according to the type chromatography
- Dimensions
- Internal diameter

## 5. [Detectors](#)

- Many types based on physical & chemical processes:
  - UV-vis
  - Refractive Index (RI)
  - Mass spectrometry (MS)
  - Electrochemical (EC)
  - NMR - novel

# Injectors

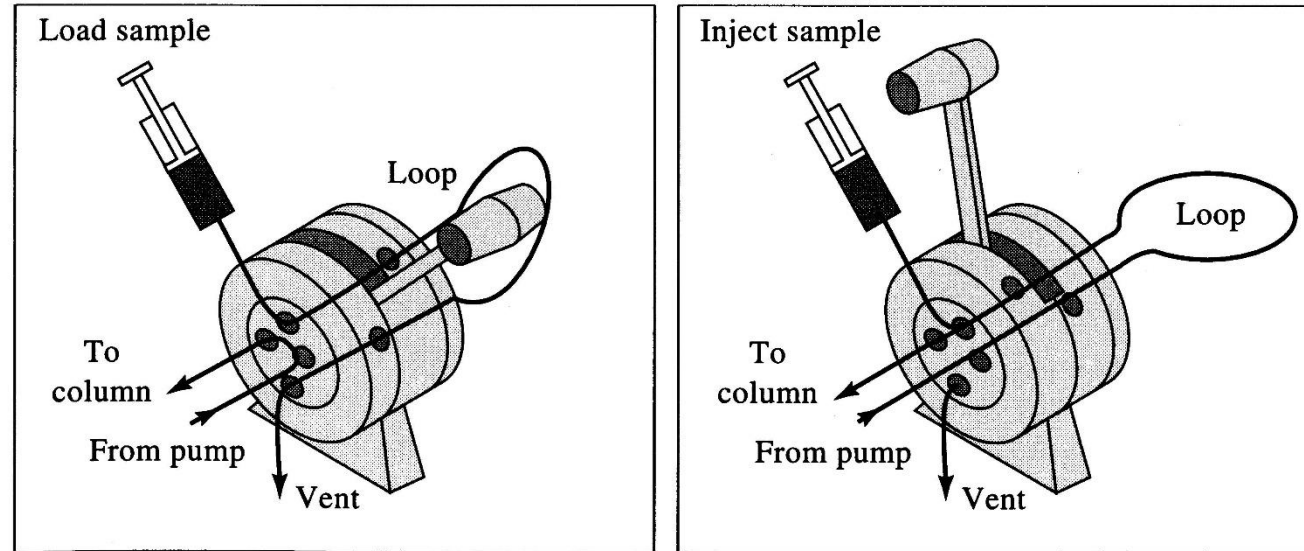

**Figure 28-7** A sampling loop for liquid chromatography. (Courtesy of Beckman Instruments, Fullerton, CA.) With the valve handle as shown on the left, the loop is filled from the syringe, and the mobile phase flows from pump to column. When the valve is placed in the position on the right, the loop is inserted between the pump and the column so that the mobile phase sweeps the sample onto the column.

# Columns

- **Short** (30-50mm) - short run times, low backpressure
- **Long** (250-300mm) - higher resolution, long run times
  
- **Narrow** ( $\leq 2.1\text{mm}$ ) - higher detector sensitivity
- **Wide** (10-22mm) - high sample loading

**Table 1: Nomenclature for HPLC Columns in Cylindrical Formats.**

Description	Dimension	Approx. typical flow-rate (velocity 1–10 mm/s)
Open tubular liquid chromatography	$< 25 \mu\text{m}$ i.d.	$< 25 \text{ nL/min}$
Nanobore column HPLC	$25 \mu\text{m} \leq \text{i.d.} \leq 100 \mu\text{m}$	25–4000 nL/min
Capillary column HPLC	$100 \mu\text{m} < \text{i.d.} < 1 \text{ mm}$	0.4–200 $\mu\text{L/min}$
Microbore column HPLC	$1 \text{ mm} \leq \text{i.d.} \leq 2.1 \text{ mm}$	50–1000 $\mu\text{L/min}$
Narrow(small)-bore column HPLC	$2.1 \text{ mm} < \text{i.d.} < 4 \text{ mm}$	0.3–3.0 mL/min
Normal-bore column HPLC	$4 \text{ mm} \leq \text{i.d.} \leq 5 \text{ mm}$	1.0–10.0 mL/min
Semipreparative column HPLC	$5 \text{ mm} < \text{i.d.} \leq 10 \text{ mm}$	5.0–40 mL/min
Preparative column HPLC	i.d. $> 10 \text{ mm}$	$> 20 \text{ mL/min}$

# Capillary (cap-) and nano-LC

- Require low flow rates (down to nl/min) either from specialized pumps or with flow splitting
- As internal diameter of the column decrease, the analyte concentration increases (in proportion to the inverse square of the diameter)
- Optimum flow rate decreases (therefore solvent consumption is reduced)
- Similar pressures
- Resolution of components increases
- Improved sensitivity
- Practical considerations:
  - Leaks difficult to find
  - Limited sample capacity
  - More prone to clogging

# Detectors

	Detection limit (g/mL)	Used with a gradient
UV absorption	$10^{-10}$	yes
IR absorption	$10^{-6}$	yes
Fluorimetry	$10^{-11}$	yes
Refractometry	$10^{-7}$	no
Conductimetry	$10^{-8}$	no
MS	$10^{-10}$	yes
Amperometry	$10^{-12}$	no

- MS ultimate detector for HPLC system in proteomics
- Separates and detects gaseous ions based on their mass-to-charge ratios (and not mass only!)
- Therefore, we must first produce gaseous ions
- Two ionisation methods are
  - MALDI (matrix assisted laser desorption ionization)
  - ESI (electrospray ionization) although it's not strictly speaking an ionisation method!

But this you already know...

Q3: MALDI and ESI can be used in on-line off-line LC-MS?

# Some set-ups

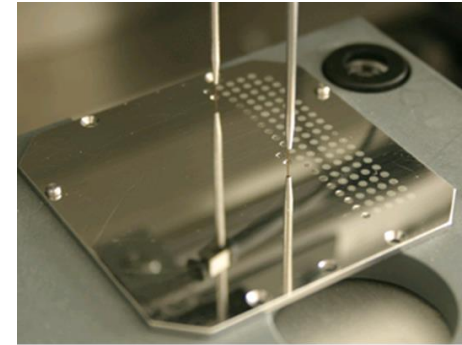
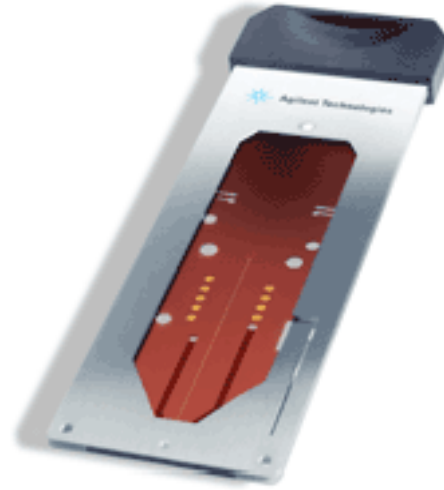

→ Into the mass spectrometer

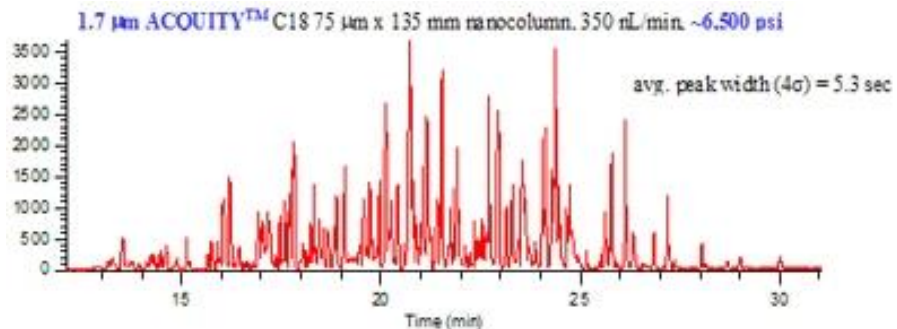

20 fmol each of enolase, phosphorylase b, hemoglobin, ADH, BSA

- Peptide + UV absorbing matrix (in 50%  $\text{CH}_3\text{CN}$ , 0.1% TFA)
- The mixture is deposited on a stainless steel target and allowed to crystallise
- The surface of the target is then irradiated (using a UV laser)
- Ions are then extracted into the mass spectrometer (detection)
- MALDI-LC is an offline technique.

## Q4: Questions?

- What are the important properties of chromatographic particles?
- What types of stationary phases can be used for chromatography?
- What is HPLC?
- What detectors are used for HPLC?
- What are the desirable properties for a detector?

# Applications of liquid chromatography in biological research

- In proteomics, generally we use a combination of chromatographic techniques in order to fractionate peptides/protein mixtures
- The key to designing a good chromatographic methodology is to maximise the protein-peptide separation by exploiting the physical and chemical properties of the various proteins to be separated

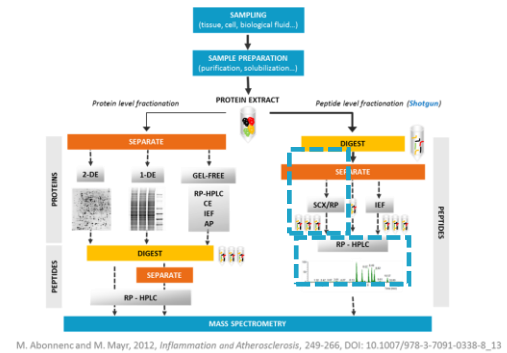
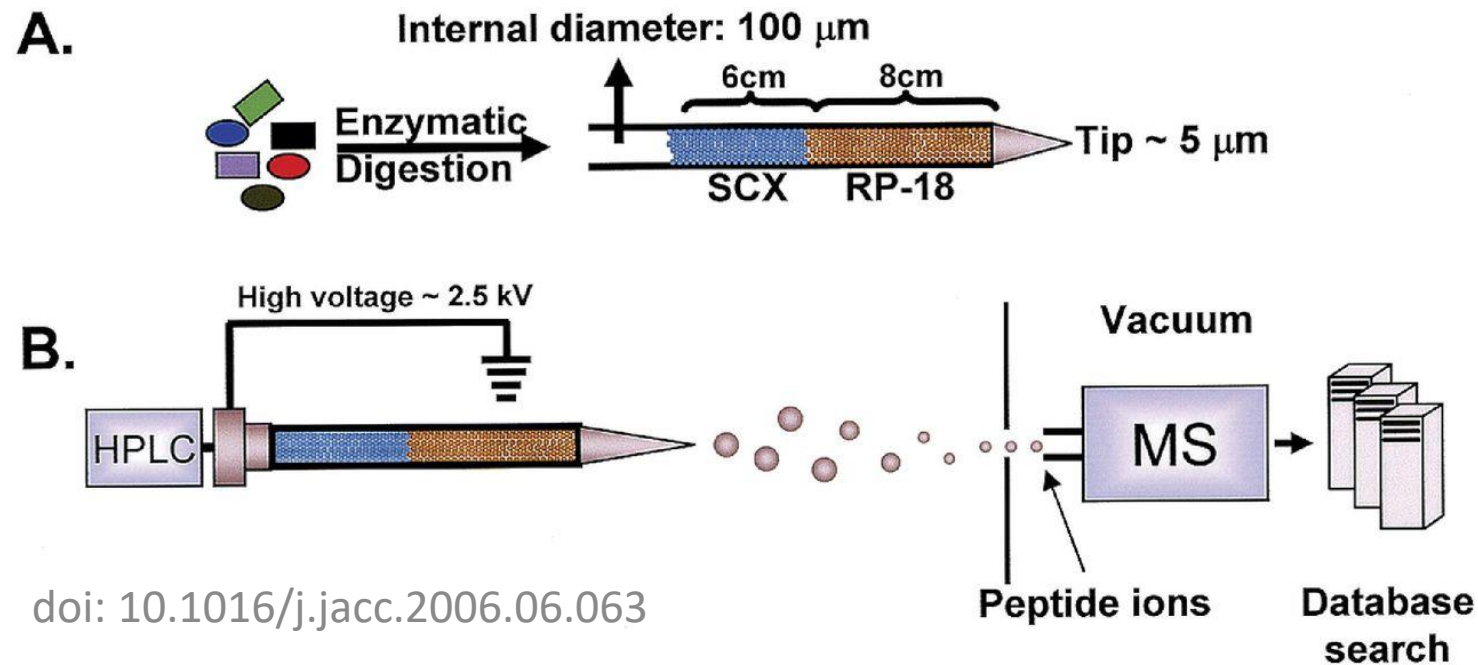

# 2D liquid chromatography

- Often, multiple fractionation steps are required to reduce the complexity of biological sample
- If we use more than one LC technique, we will achieve multi-dimensional separation of our proteins/peptides!
- For example, peptides are separated according to their charge (1<sup>st</sup> dimension), on a strong cation exchange (SCX). The peptides are then loaded onto a C18 RP column and separated according to their hydrophobicity (2<sup>nd</sup> dimension)
- Or peptides are separated according to their hydrophobicity at basic pH (1<sup>st</sup> dimension), onto a C18 RP column. The peptides are then loaded onto a C18 RP column and separated according to their hydrophobicity at acidic pH (2<sup>nd</sup> dimension)

# Applications of liquid chromatography in biological research

## IMAC (or titanium dioxide (TiO<sub>2</sub>) beads) in phosphoproteomics

- Protein phosphorylation is directly or indirectly involved with most cell processes
- Phosphorylation acts like a switch, turning the function of a protein on or off
- Phosphorylation is regulated by kinases, which transfer a phosphate group from ATP to another protein
- Dephosphorylation is regulated by phosphatases, which remove the phosphate group
- Primarily, the residues on the proteins that are phosphorylated are tyrosine, serine and threonine

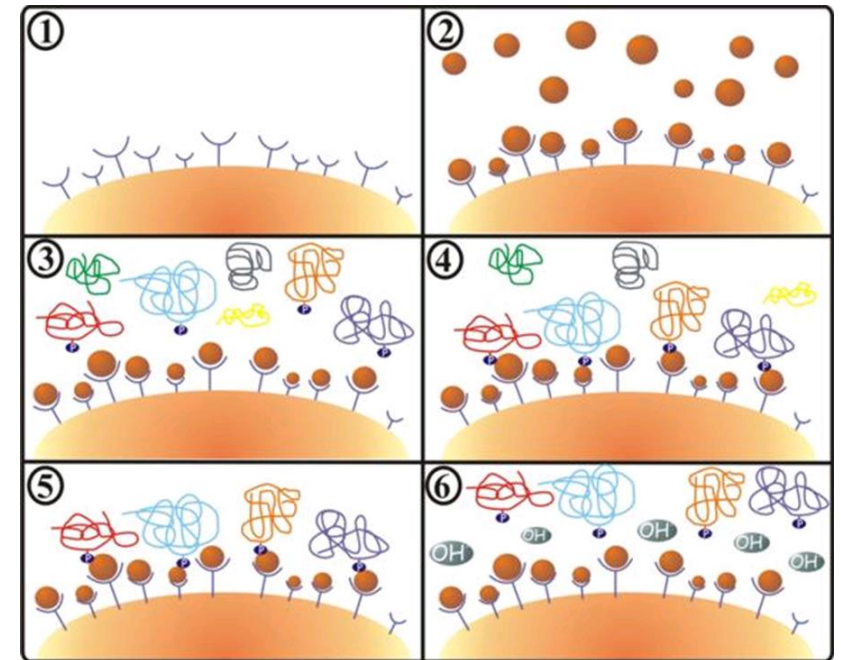

- (1) Stationary phase with covalently bound chelating-region
- (2) Loading with metal ions (e.g., Fe(III))
- (3) Removal of excess ions and injection of sample
- (4) Phosphorylated peptides are bound under acidic conditions
- (5) non-phosphorylated species are removed.
- (6) Elution of phospho-peptides by shifting pH (e.g., with ammonium hydroxide)

# Q6: Exercise

- A tryptic hydrolysate of a-casein was analysed by C18 RP LC-ESI-MS.
- Assuming full tryptic digestion (C-terminal to K and R) with no missed cleavages. What is the order of elution (underlined serines) ?

1. Generate peptide sequences

VNELSK ③

② DIG SESTEDQAME DIK

QMEAESI SSEEIVPNS VEQK ①

④ VPQLEIVPNS AEER

What influences the retention time in RP LC?

Hydrophobicity  
Hydrophilic peptides elute first

Put the peptides in the increasing order of hydrophobicity

## Q7: Question?

- You've just digested your cell lysate and by mistake you've added SDS (a negatively charged detergent). How do you propose to rescue your digest before an LC-MS analysis?

# Summary

- In proteomics, main separations are performed with electrophoresis or liquid chromatography...
- But the mass spectrometer can also be used to better separate complex mixtures

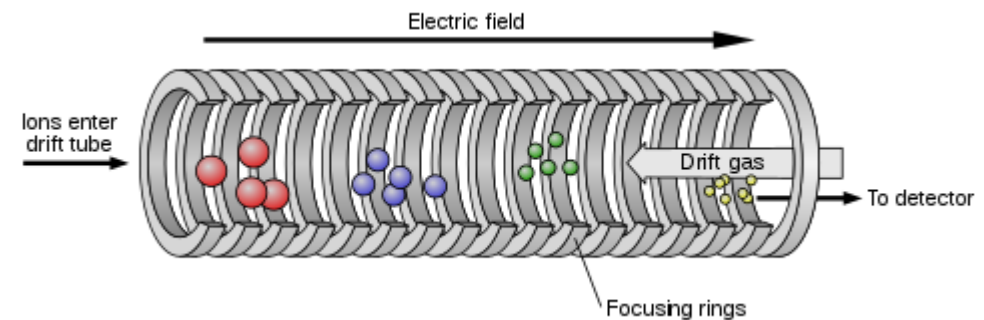
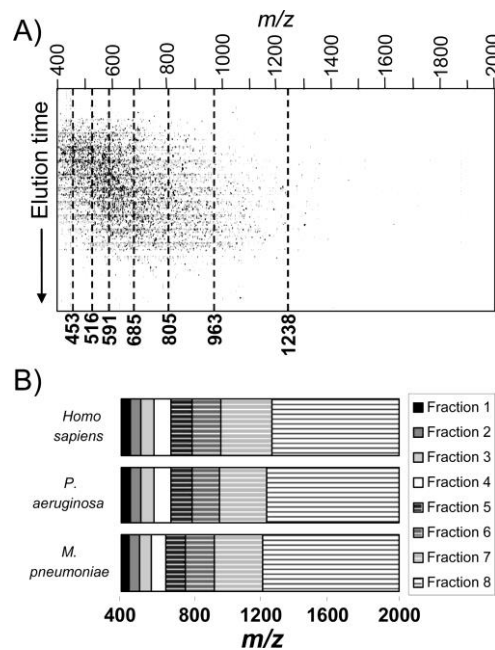

[https://en.wikipedia.org/wiki/Ion-mobility\\_spectrometry](https://en.wikipedia.org/wiki/Ion-mobility_spectrometry)